

DD214NE - Display device for digital sensors

- Preset counter with two presets
- Display 6-digits
- Batch counter, totalizer, hour counter
- Operating mode, start count, scaling factor, momentary signal time programmable
- Connection: Sensors with incremental digital output
- Batch counter with multiplier
- Preset mode programmable
- Two limits as optocoupler



Additional equipment model DD214NE(01)

- Interface RS232
- Analogue output
- Two limits as relay output

DD214NE is a display for two digital sensor signals. The display has several integral counting functions. With option 01, the display becomes a process display. Production can be controlled with two programmable limit switches (relay contacts).

Dimensions (Dimensions in mm, not to scale.)

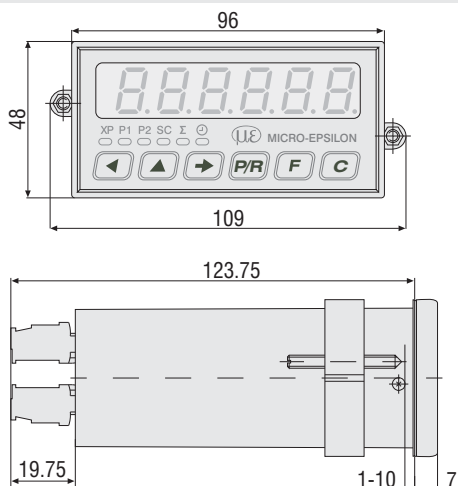

Block circuit diagram

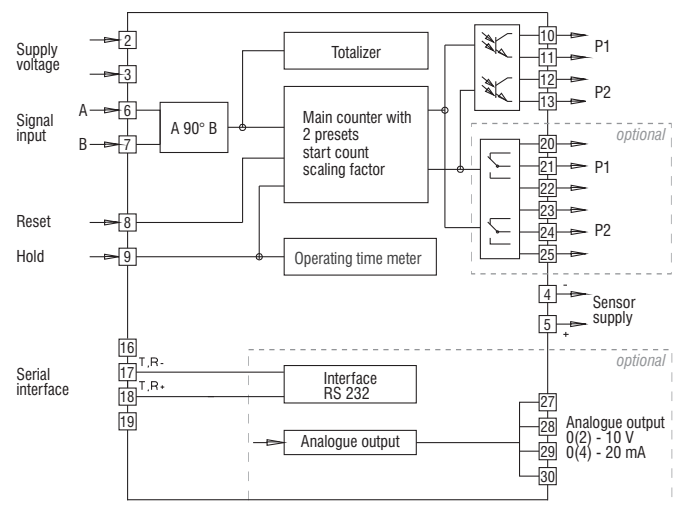

Technical data - electrical ratings	
Power supply	24 VDC \pm 10 %
Power consumption	7 VA, 5 W
Sensor supply	12...26 VDC / max. 100 mA
Display	LED, 7-segment display
Number of digits	6-digits
Digit height	14 mm
Function	preset counter; main counter with 2 presets; batch counter with 1 preset; totalizer; hour counter
Scaling factor	0.0001 ... 9999.99
Multitplier / batch counter	1...999
Count modes	Adding or subtracting; A-B (difference counting); A+B total (parallel counting); Up/Down, A 90° B phase evaluation
Counting frequency	3 Hz, 25 Hz, 10 kHz programmable
Operating modes	Step preset, main preset, parallel alignment, trailing preset
Data memory	> 10 years in EEPROM
Reset	Button, electric or automatic
Outputs electronic	Optocoupler
Outputs relay	Potential-free change-over contact (optional)
Output holding time	0.01 ... 99.99 s
Analogue output	0(2)...10 V, 0(4)...20 mA (optional)
Interfaces	RS232 (optional)
Standard DIN EN 61010-1	Protection class II; overvoltage category II; pollution degree 2
Emitted interference	DIN EN 61000-6-3
Interference immunity	DIN EN 61000-6-2
Programmable parameters	Operating modes, sensor logic, scaling factor, count mode, control input
Approvals	UL/cUL, CE conform

Technical data - mechanical design	
Temperature	Operating: -10...+50 °C; Storing: -20...+70 °C
Relative humidity	80 %, non-condensing
E-connection	Plug-in screw terminals
Core cross-section	1,5 mm ²
Protection DIN EN 60529	IP 65 face with seal
Operation / keypad	Membrane with softkeys
Housing type	Built-in housing
Dimensions	W x H x L 96 x 48 x 124 mm
Cutout dimensions	96 x 45 mm (+0.6)
Installation depth	123.75 mm
Mounting	Clip frame
Weight	Approx. 350 g (AC), 250 g (DC)
Material housing	Makrolon 6485 (PC)