



**vacCONTROL 810**  
Vacuum monitoring  
system for cans, jars  
and bottles

## vacCONTROL

monitors the integrity of the vacuum in can, jars and bottles and analyses the results statistically. Operation is completely automatic and without contact. Faulty cans can be sorted out immediately. The system is suitable for diverse types of caps and a wide range of diameters. Environmental influences like humidity and temperature variations have no influence on the proper operation of the vacCONTROL equipment.

## vacCONTROL

operates wear- and maintenance free. The electronics is based on a non-contacting displacement measuring system with a sequential analysis of the signals by means of a micro-computer. The electronics is a modular system housed in a waterproofed cabinet. The sensor is mounted above the conveyor behind the filling and sealing machine. The electronics can be installed up to 3 m from the sensor.

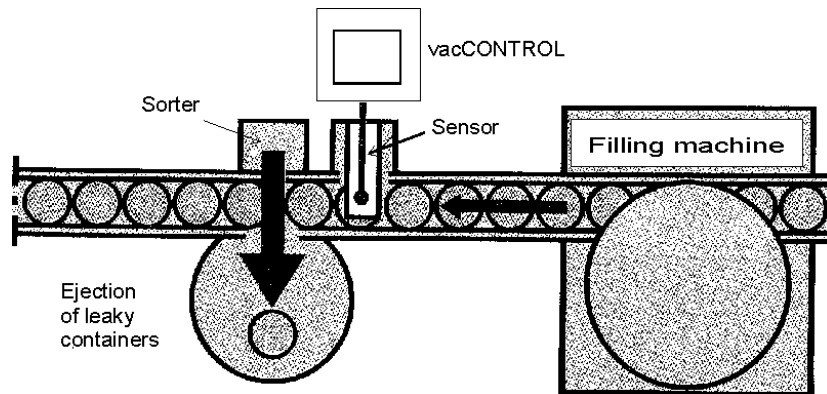

## Features

- Highest accuracy by precision-sensor from a specialist
- Clear, large display
- Simple operation
- Selectable languages
- Stainless steel housing
- Easy integration to machine controls
- Long-term investment by software-download from PC
- Graphic display of the shape of the cap
- Program selection of pre-adjusted products/cans
- Password
- Interface for sorter, displacement sensor, light barrier, transport speed, optical speed
- Large wiring space for fast and easy electrical connection

## Measuring Principle

In a non-contacting process the vacCONTROL 810 system measures the cap deflection caused by the vacuum. A sensor „scans“ the cap shape while the individual glasses pass the measuring point. The micro-computer unit stores the values and uses them to calculate the cap deflection as a function of the internal pressure.

vacCONTROL 810 compares the values with a preset deflection set value and decides about the tightness of the glass. If the cap deflection is not large enough, an eject pulse of adjustable length is generated. This pulse controls a sorter which separates the glasses into good (sealed) and bad (leaky). In combination with a light barrier or an optical switch the system also sorts out glasses that have no cap.

Counters record the total number of containers tested and the number of rejects. In parallel with the tightness check the micro-computer runs a statistics program which provides data on the corresponding actual throughput.

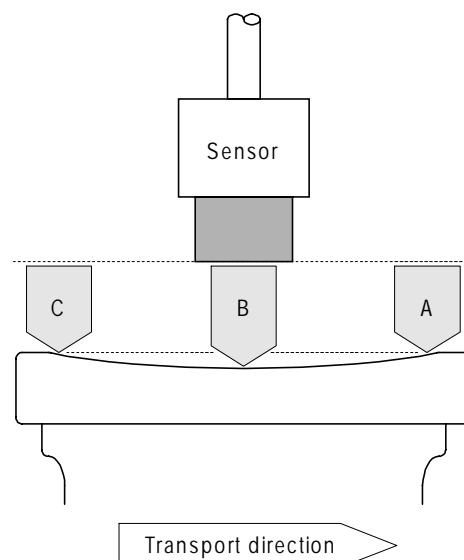

## Technical Data

Capacity: max. 90.000 units / h

Displacement sensor	Offset distance	Measuring range
HA-141S	1 mm	3 mm
HA-162S	1 mm	5 mm

Operating voltage: 240 Vac, 50/60 Hz  
(alternative 120 Vac, 50/60 Hz selectable)

Power consumption: 40 VA

Fuse: 1 x 0,315 A slow (240 Vac)  
1 x 0,63 A slow (120 Vac)

Weight: 8 kg

Dimensions(mm): 420 \* 380 \* 160

Protection class: IP 65

Operating temperature: 0 up to +50 °C

Cable connections: terminated strip connectors 0,128 up to 2,08 mm<sup>2</sup>

Serial interface: RS 232: 8 data bits, no parity, 2 stop bits,  
varying baud rate  
CAN-Bus

### Inputs:

Displacement sensor

Light barrier / caps without gap (PNP)

Optical switch / tilted can (PNP)

Rotary encoder (PNP)

### Outputs:

Sorter signal: 24 Vdc; 0,5 A  
Output type : Opto insulated  
Pulse length: max. 200 msec.  
Delay: max. 20 sec.  
Accuracy: 1 msec

In operation: 24 Vdc; 0,1 A  
Output type: Opto insulated

Stop signal: 24 Vdc; 0,1 A  
output type: Opto insulated

## Drawings Housing

(Not to scale)

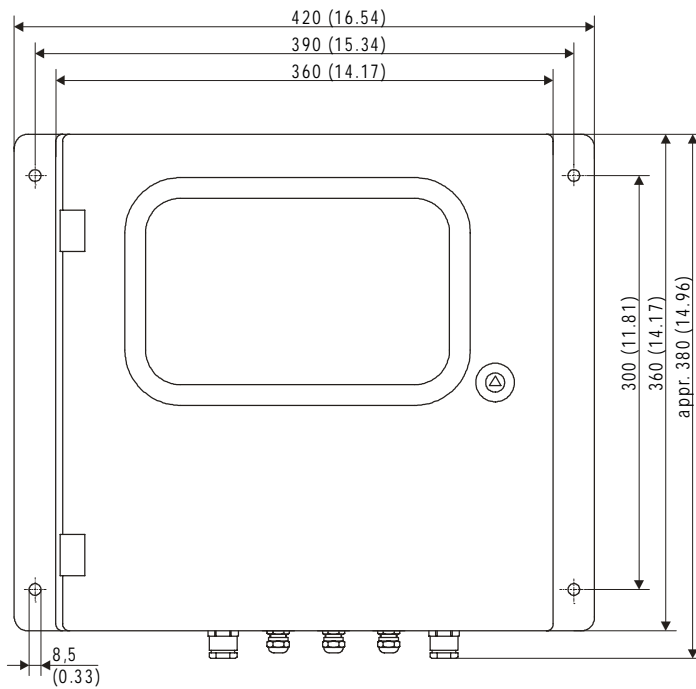

Legend:  
mm  
(inches)

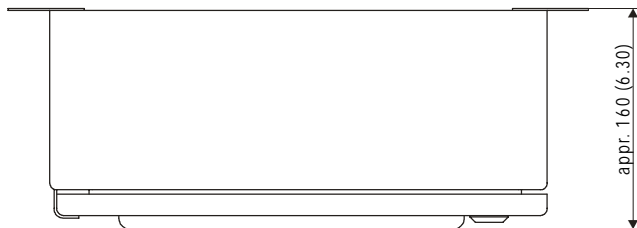

## Drawings Displacement Sensors

(Not to scale)

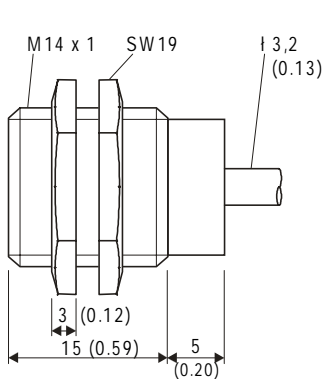

Sensor HA-141S

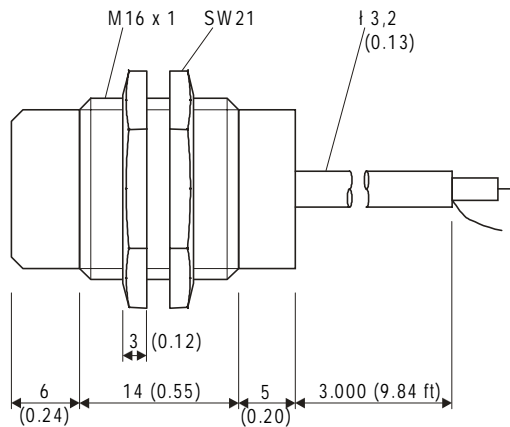

Sensor HA-162S

Y9761062-B/mssc/09.98