

colorSENSOR OT Series

colorSENSOR OT-3-HR-30

- Measuring range typ. 10 mm ... 40 mm
- Polarization filter (very intense reduction of gloss effect)
- Up to 31 colors can be stored
- RS232 interface (USB adapter is available)
- 8x super-bright white-light LED, focused (AC-/DC-/PULSE-operation or OFF for luminous objects can be switched)
- Color detection, contrast detection, and gray scale detection
- Insensitive to outside light
- Brightness correction can be activated
- Switching frequency up to 35 kHz
- Several TEACH functions (via PC, PLC, or push button)
- Various evaluation algorithms can be activated
- "BEST HIT" mode ("human color assessment")
- Switching state display by means of 5 yellow LEDs
- Temperature compensated in climatic cabinet
- Averaging can be activated (from 1 up to over 32000 values)
- Color control of luminous objects (LEDs, halogen lamps, displays, ...)
- 3-color filter detector (true color detector: "human color perception")

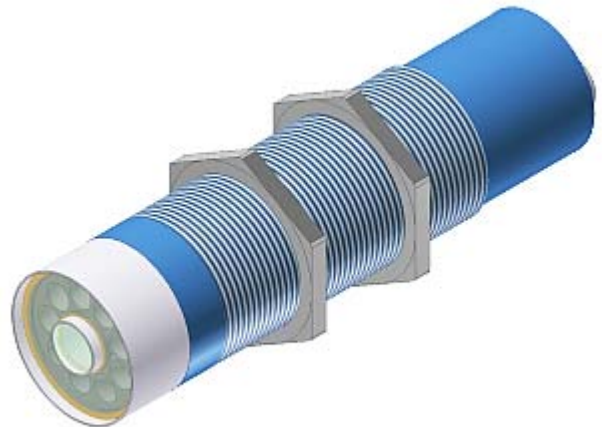

Design

Product name:

colorSENSOR OT-3-HR-30-16

colorSENSOR OT-3-HR-30-8

(incl. Software colorCONTROL-S)

d5 =By use of an aperture \varnothing 5 mm the detection range at the working distance of 30 mm will be reduced to 5 mm.

Mounting accessories:
(p. 7)

FL-34 (flange)

WFL-34 (flange)

Optics holding device
(aluminum, anodized)

Receiver optics and transmitter optics with 8x white light LED incl. 3-color filter detector (True Color) and polarisation filter (scratch-resistant optics cover made of glass)

4-pole fem. connector
Binder Series 707
RS232-interface

Connecting cable:
CAB-M5-4P-St-ge; xm-PUR; RS232 or
CAB-M5-4P-St-ge; xm-PVC; USB

TEACH button
(external teaching
via input IN0)

8-pole fem. connector
Binder Series 712
(connection to PLC)

Connecting cable:
CAB-M9-8P-St-ge; xm-PUR; open

LED display:
Switching state indication
by means of 5 yellow LED

Sturdy aluminum
housing, anodized
in blue

Mounting screws
(M34)

Technical Data

Type	OT-3-HR-30-8	OT-3-HR-30-16
Light source	8x white light LED	
	AC-, DC-operation (adjustable or OFF in case of luminous objects adjustable via software)	
Illumination technique	Polarisation filter, focused	
Effect of illumination	very intense reduction of gloss effects, adapted for highly reflected surfaces	
Target distance	typ. 10 mm up to 40 mm ideal distance at 30 mm	
Light spot size	Ø 8 (8 dia.) mm at 30 mm	Ø 16 (16 dia.) mm at 30 mm
Reproducibility	in the X, Y color range each 1 digit at 12-bit A/D conversion	
Color distance	$\Delta E \geq 0.8$	
Receiver	3-color filter detector (TRUE COLOR Detector, color filter bend according to CIE 1931)	
Alternating light operation	AC: typ. 10 kHz up to 40 kHz depends on the gain step (AMP1 up to AMP8) DC: adjustable via PC software	
Ambient light	up to 5000 Lux (in AC-operation)	
Protection class	IP 67 (Optics), IP64 (Controller)	
Current consumption	typ. 320 mA	
Interface	RS 232 (USB optional)	
Connector type	to PLC: 8-pole female connector (Binder series 712) to PC: 4-pole female connector (Binder series 707)	
Connection cable	to PLC: CAB-M9-8P-St-ge; xm-PUR; open to PC: CAB-M5-4P-St-ge; xm-PUR; RS232; CAB-M5-4P-St-ge; xm-PVC; USB	
Housing material	Aluminum, anodized in black	
Operating temperature	-20°C - + 55°C (-4°F up to +131°)	
Storage temperature	-20°C - +85°C (-4°F up to +185°F)	
Pulse lengthening	adjustable 0 ms up to 100 ms	
Max. switching current	100 mA, short-circuit-proof	
Switching frequency	max. 30 kHz (depends on the number of teach-colors and averaging value)	
Outputs	OUT 0 - OUT 4, digital (0V/+Ub), short-circuit-proof 100 mA max. switching current npn-, pnp-available (bright-, dark-switching can be switched over)	
Averaging	over 32768 values max.	
Voltage supply	+24 VDC ($\pm 10\%$), protected against polarity reversal, overload protected	
Switching state display	Visualization by means of 5 yellow LED's	
Color memory capacity	non-volatile EEPROM with parameter sets for 31 colors max.	
TEACH button	for external teaching of color reference values via input IN0	
Temperatur drift X,Y	< 0.01% / K	
Signal gain	8 steps (AMP1 - AMP8), adjustable	
EMC test	according to DIN EN 60947-5-2	
Color spaces	X/Y INT; s/i M (Lab)	

Dimensions

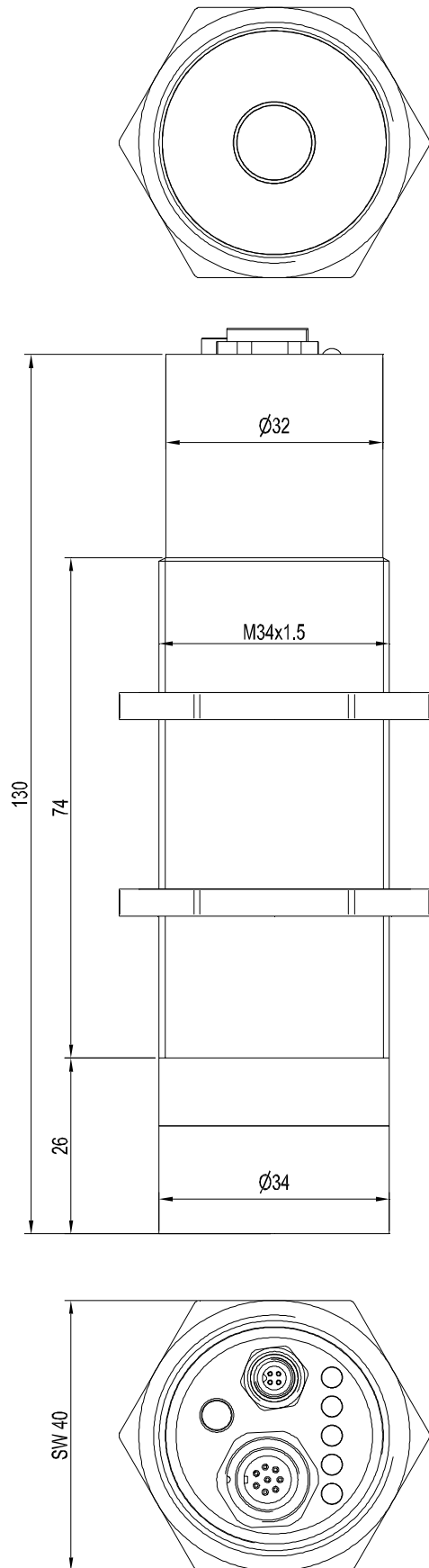

All dimensions in mm



Connector Assignment

Connection to PLC:

8-pole fem. connector Binder Series 712

Pin: Color: Assignment:

1	white	GND (0V)
2	brown	+24VDC ($\pm 10\%$)
3	green	IN0
4	yellow	OUT0
5	grey	OUT1
6	pink	OUT2
7	blue	OUT3
8	red	OUT4

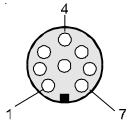

Connecting cable to PLC:
CAB-M9-8P-St-ge; xm-PUR; open

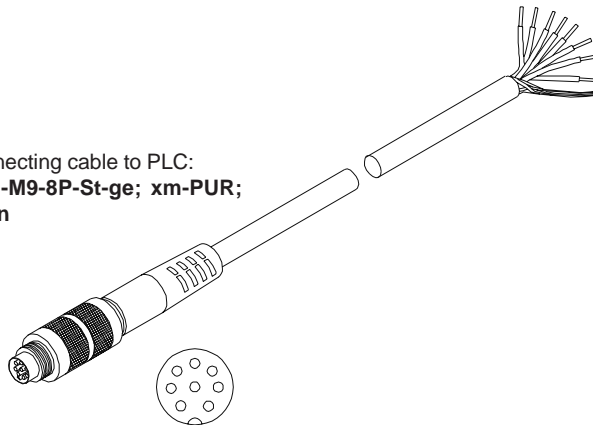

Connecting cable:

CAB-M9-8P-St-ge; 2m-PUR; open
CAB-M9-8P-St-ge; 5m-PUR; open
(Standard length 2 m)

Connection to PC:

4-pole fem. connector Binder Series 707

Pin: Assignment:

1	+24VDC (+Ub, OUT)
2	GND (0V)
3	RxD
4	TxD

Connecting cable:

CAB-M5-4P-St-ge; 2m-PUR; RS232
CAB-M5-4P-St-ge; 5m-PUR; RS232
(Standard length 2 m)

alternatively:

Connecting cable (incl. driver software):
CAB-M5-4P-St-ge; 2m-PVC; USB
CAB-M5-4P-St-ge; 5m-PVC; USB
(Standard length 2 m)

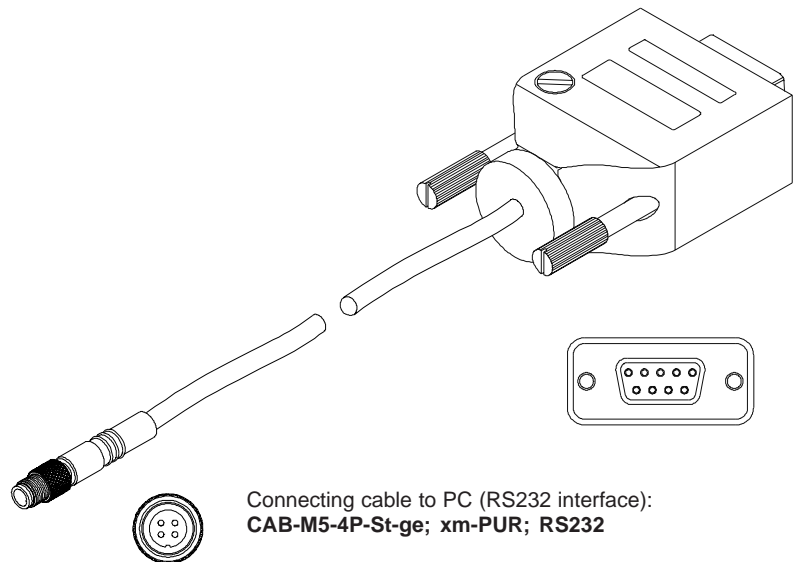

Connecting cable to PC (RS232 interface):
CAB-M5-4P-St-ge; xm-PUR; RS232

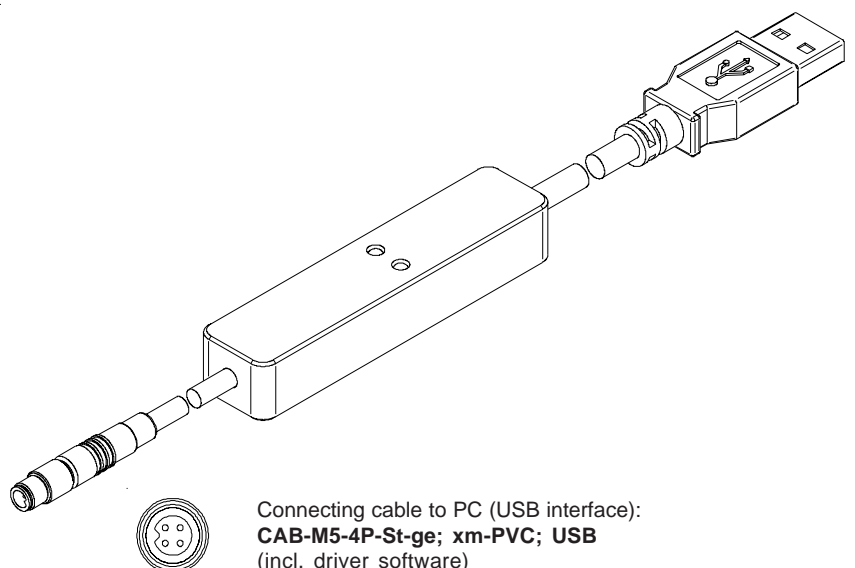

Connecting cable to PC (USB interface):
CAB-M5-4P-St-ge; xm-PVC; USB
(incl. driver software)

Measuring Principle

Measuring principle of the color sensors of colorSENSOR OT-3 series:

The colorSENSOR OT-3 provides highly flexible signal acquisition. For example, the sensor can be operated in alternating-light mode (AC mode), which makes the sensor insensitive to extraneous light. It also can be set to constant-light mode (DC mode), which makes the sensor extremely fast and allows a scan-frequency of up to 35 kHz.

An OFF function turns off the integrated light source at the sensor and changes to DC operation. The sensor then can detect so-called "self-luminous objects". In PULSE operation extremely dark surfaces can be reliably detected. With the stepless adjustment of the integrated light source and the selectable gain of the receiver signal the sensor can be set to almost any surface or any "self-luminous object".

When the integrated light source of the colorSENSOR OT-3 color sensor is activated, the sensor detects the radiation that is diffusely reflected from the object. As a light source the colorSENSOR OT-3 color sensor uses a white-light LED with adjustable transmitter power. An integrated 3-fold receiver for the red, green, and blue content of the light that is reflected from the object, or the light that is emitted by a "self-luminous object", is used as a receiver. As mentioned above, a special feature here is that the gain of the receiver can be set in 8 steps. This makes it possible to optimally adjust the sensor to almost any surface and to different "self-luminous objects".

The colorSENSOR OT-3 color sensor can be "taught" up to 31 colors. For each of these taught colors it is possible to set tolerances.

In X/Y INT or s/i M mode these tolerances form a color cylinder in space. In X/Y/INT or s/i/M mode the tolerances form a color sphere in space. Color evaluation according to s/i M is based on the lab calculation method. All modes can be used in combination with several operating modes such as "FIRST HIT" and "BEST HIT". Raw data are represented with 12 bit resolution.

Color detection either operates continuously or is started through an external PLC trigger signal. The respective detected color either is provided as a binary code at the 5 digital outputs or can be sent directly to the outputs, if only up to 5 colors are to be detected. At the same time the detected color code is visualised by means of 5 LEDs at the housing of the colorSENSOR OT-3. [\[Please note: Visualisation by means of LEDs not available with colorSENSOR LT-1-LC-20 types.\]](#)

With a TEACH button at the sensor housing the color sensor can be taught up to 31 colors. For this purpose the corresponding evaluation mode must be set with the software. The TEACH button is connected in parallel to the input IN0 (green wire at cable CAB-M9-8P-St-ge; xm-PUR; open). [\[Please note: TEACH button not available with colorSENSOR LT-1-LC-20 types.\]](#)

Parameters and measurement values can be exchanged between a PC and the colorSENSOR OT-3 color sensor through the serial RS232 interface. All the parameters for color detection also can be saved to the non-volatile EEPROM of the colorSENSOR OT-3 color sensor through this serial RS232 interface. When parameterisation is finished, the color sensor continues to operate with the current parameters in STAND-ALONE mode without a PC.

The sensors of the colorSENSOR OT-3 series can be calibrated (white-light balancing). Balancing can be performed to any white surface. A ColorChecker™ table with 24 color fields is available as an alternative.

Visualization

Visualization of the color code:

The color code is visualised by way of 5 yellow LEDs at the housing of the colorSENSOR OT-3 color sensor. At the same time in the binary mode (OUT BINARY) the color code indicated on the LED display is output as 5-bit binary information at the digital outputs OUT0 to OUT4 of the 8-pin colorSENSOR OT-3/PLC socket.

The colorSENSOR OT-3 color sensor is able to process a maximum of 31 colors (color code 0 ... 30) in accordance with the corresponding rows in the COLOR TEACH TABLE. An "error" respectively a "not detected color" is displayed by the lighting of all LED (OUT0 ... OUT4 digital outputs are set to HIGH-level).

In the DIRECT mode (OUT DIRECT HI or OUT DIRECT LO) the maximum numbers of colors to be taught is 5 (color no. 0, 1, 2, 3, 4). If DIRECT HI is activated, the specially digital output is set to HI, while the other 4 are set to LO. If the current color does not correspond with any of the teach-in colors, all digital outputs are set to LOW (no LED is lighting).

If DIRECT LO is activated, the specially digital output is set to LO, while the other 4 are set to HI. If the current color does not correspond with any of the teach-in colors, all digital outputs are set to HIGH (all LED are lighting).

LED-Display

LED display:

The color code is visualized by means of 5 yellow LEDs at the housing of the color sensor. At the same time the color code indicated at the LED display is output as 5-bit binary information at the digital outputs OUT0 ... OUT4 of the 8-pole PLC connector.

In the DIRECT mode the maximum number of color codes to be taught is 5. These 5 color codes can be directly output at the 5 digital outputs. The respective detected color code is displayed by means of the 5 yellow LEDs at the color sensor housing.

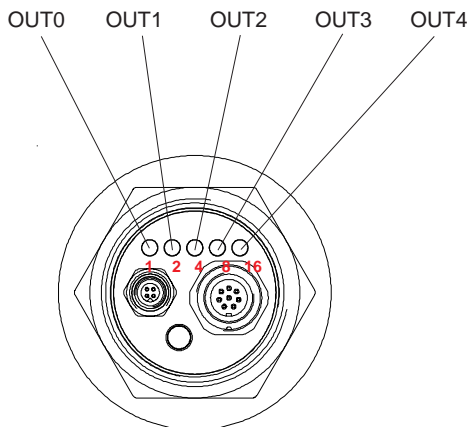
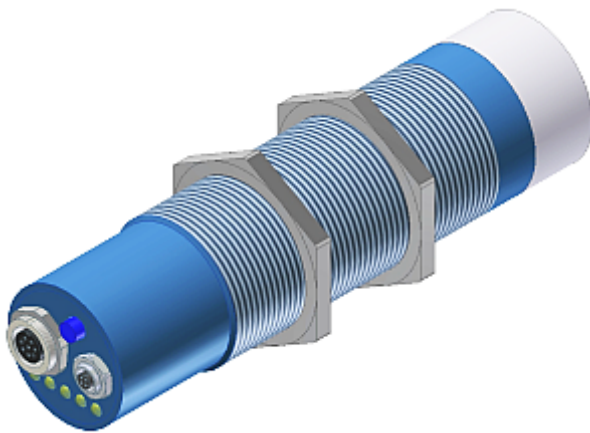

○ ○ ○ ○ ○ 0	● ○ ○ ○ ○ 1	○ ● ○ ○ ○ 2
● ● ○ ○ ○ 3	○ ○ ● ○ ○ 4	● ○ ● ○ ○ 5
○ ● ● ○ ○ 6	● ● ● ○ ○ 7	○ ○ ○ ● ○ 8
● ○ ○ ● ○ 9	○ ● ○ ● ○ 10	● ● ○ ● ○ 11
○ ○ ● ● ○ 12	● ○ ● ● ○ 13	○ ● ● ● ○ 14
● ● ● ● ○ 15	○ ○ ○ ○ ● 16	● ○ ○ ○ ● 17
○ ● ○ ○ ● 18	● ● ○ ○ ● 19	○ ○ ● ○ ● 20
● ○ ● ○ ● 21	○ ● ● ○ ● 22	● ● ● ○ ● 23
○ ○ ○ ● ● 24	● ○ ○ ● ● 25	○ ● ○ ● ● 26
● ● ○ ● ● 27	○ ○ ● ● ● 28	● ○ ● ● ● 29
○ ● ● ● ● 30	● ● ● ● ● Error or „not detected“	

Mounting Accessories

FL-34 (flange):

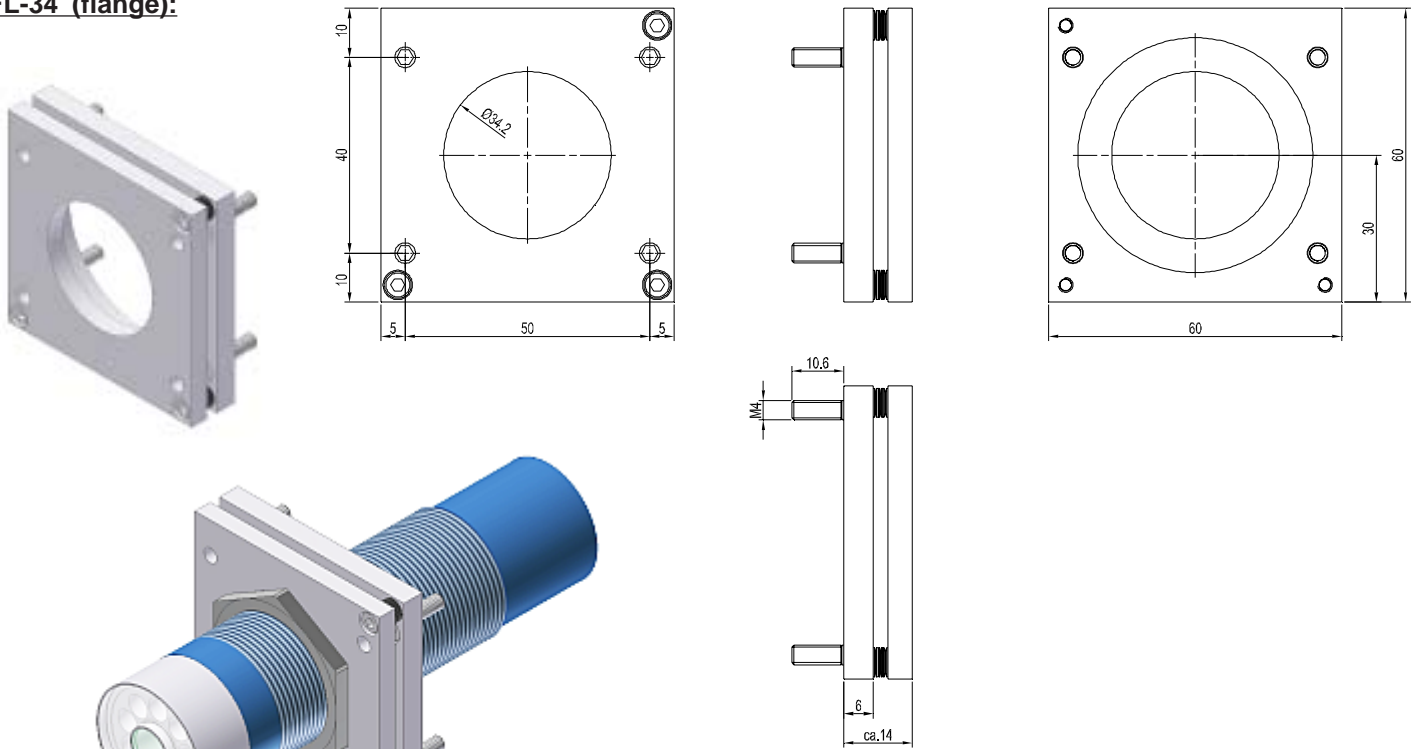

Example: FL-34 with colorSENSOR OT-3-GL-30 mounted

WFL-34 (flange, angle type 90°):

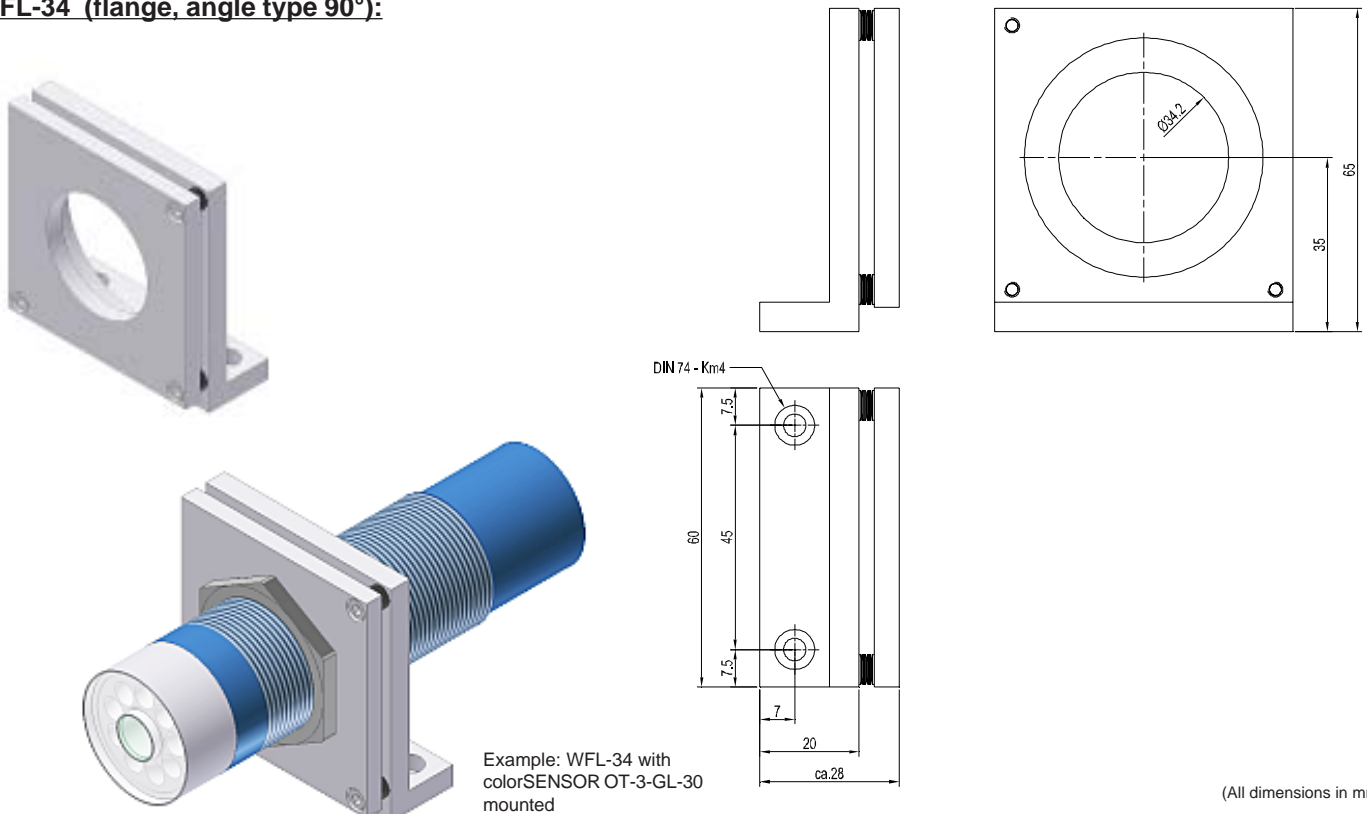

Example: WFL-34 with colorSENSOR OT-3-GL-30 mounted

(All dimensions in mm)



Application Example

Surface inspection of cast pipes

Centrifugally cast pipes must be inspected for their surface quality. Bad surface quality is characterized by the occurrence of frequent, larger depressions which as a whole make the surfaces appear brighter and more diffuse. Good surface quality, on the other hand, only shows slight depressions, and the surface appears more homogeneous and blank, and therefore also darker.

With the colorSENSOR OT-3-HR-30 color sensor high-quality surfaces can be reliably differentiated from low-quality surfaces. Direct reflection is suppressed by polarised white light, a good surface therefore appears considerably darker than a bad surface. The inspection was performed at a sensor distance of approx. 30 mm.

