



# More Precision

optoNCDT ILR // Laser distance sensors





- Measuring range up to 10m on diffuse reflecting targets
- Short response time
- Excellent price-performance ratio
- Fast sensor set configuration via touch keys

Gaging sensors of the series optoNCDT 1020/1100/1150 are designed for non-contacting measurements at distances of up to 10m. These measurements are required for position determination, attendance checking, type classification and for machine control in numerous fields of application.

#### Precise sensor alignment

The aiming laser can be turned on for accurate alignment of the sensor with the measurement object. For mounting the sensor a mounting bracket and a fine adjuster are available as accessories, which simplify the precise alignment of the sensor to the measurement object.

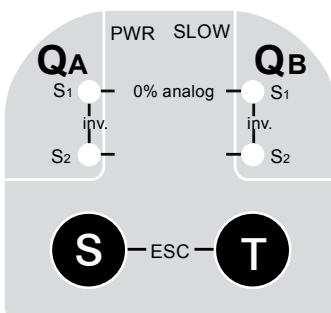
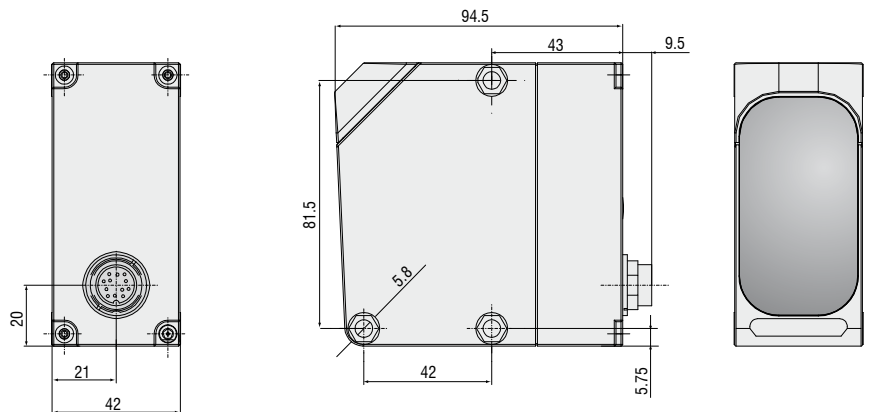

ILR1020: Limit switch programming via touch keys



ILR1100/ILR1150: Limit switch programming via software

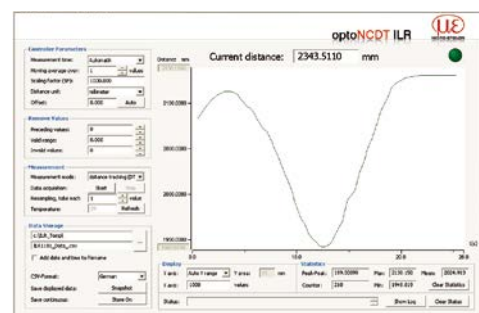

Model		ILR1020-6	ILR1100-6	ILR1150-10
Measuring range	black 6%	0.2 ... 2.5m	0.5 ... 2m	0.5 ... 3m
	grey 10%	0.2 ... 6m	0.5 m ... 4m	0.5 ... 7m
	white 90%	0.2 ... 6m	0.5 m ... 6m	0.5 ... 10m
Linearity		±40mm	±10mm	±8mm
Resolution		1 ... 5mm	0.1mm	0.1mm
Repeatability		±10/±15mm <sup>1)</sup>	±5mm	±4mm
Response time		80/13ms <sup>1)</sup>	12ms	12ms
Laser class	measuring laser	IR 905nm, laser class 1		IR 900nm, laser class 1
	sighting laser	red 650nm, laser class 2		
Operation temperature <sup>2)</sup>		-10° ... +50°C; -20° ... +50°C in continuous operation (humidity 5 - 95%, no condensation)		
Storage temperature		-30° ... +75°C		
Limit outputs		QA/QB (max. 100 mA)		
Switching points		free adjustable (teach in)	adjustable in 1-mm-steps	
Switching hysteresis		30mm	min. 20mm (adjustable)	min. 10mm (adjustable)
Plausibility output		-	QP (max. 50mA)	
Service output		-	QS (max. 50mA)	
Serial interface		-	RS422 (2.9ms at 57.6kBaud) SSI - compatible (GRAY/BINÄR adjustable) (SSI cycle 80µs)	
Bus interface		-	Profibus or DeviceNet via respective gateway (accessory)	
Analogue output			4 - 20mA	
Temperature stability		<1.2mm/°C	<0.5mm/°C	<±5mm absolute
Supply			18 - 30 VDC	
Max. consumption			<3W at 24V	
Connection		5-pin connector M12	12-pin connector M16	
Protection class			IP 67	
Material (housing)			ABS shock resistant	
Vibration	EN 60947-5-2	10 - 55 Hz, amplitude 1.5mm, period 5min. at resonant frequency or 55Hz, stress time 30min. per axis		
Shock	EN 60947-5-2	acceleration 30g, pulse duration 11ms, half sinusoid, 3 shocks/axis		
Weight		appr. 200g	appr. 230g	
Accessoires			page 14 - 15	

All data regarding accuracy and distance are based on the specified surface at constant ambient conditions and with a minimum operating time of 15 minutes.

<sup>1)</sup> slow/fast

<sup>2)</sup> when crossing 0°C an additional heating may be required



Operating Mode Laser Class 1 (Infrared)
Setup Mode Laser Class 2 (Visible - Red) <b>Do not stare into beam</b> λ: 650 nm t <sub>p</sub> : 0,25 µs; T: 2,5 µs P <sub>max</sub> : 3 mW
EN 60825-1. 10/2003

optoNCDT ILR 1020/1100/1150 use a semi-conductor class 1 laser (operating mode) and a semiconductor class 2 laser (setup mode). With these classes no protection is needed.

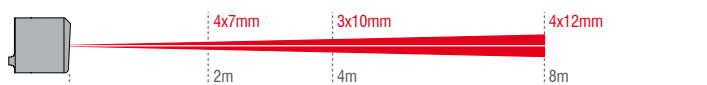
Spot diameter ILR1020

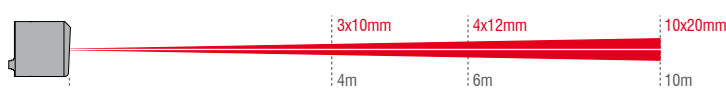

Spot diameter ILR1100/1150



## High performance sensors made by Micro-Epsilon



Sensors and systems for displacement and position



Sensors and measurement devices for non-contact temperature measurement



2D/3D profile sensors (laser scanner)



Optical micrometers, fibre optic sensors and fibre optics



Colour recognition sensors, LED analyzers and colour online spectrometer

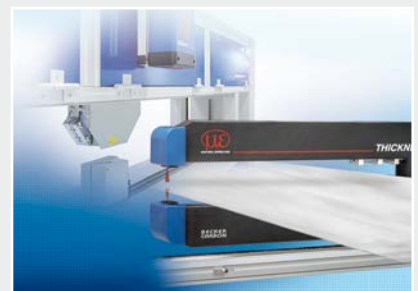

Measurement and inspection systems



MICRO-EPSILON Headquarters  
Koenigbacher Str. 15 · 94496 Ortenburg / Germany  
Tel. +49 (0) 8542 / 168-0 · Fax +49 (0) 8542 / 168-90  
info@micro-epsilon.com · www.micro-epsilon.com

MICRO-EPSILON UK Ltd.  
No.1 Shorelines Building · Shore Road · Birkenhead · CH41 1AU  
Phone +44 (0) 151 355 6070 · Fax +44 (0) 151 355 6075  
info@micro-epsilon.co.uk · www.micro-epsilon.co.uk