



More Precision

capaNCDT // Capacitive sensors for displacement, distance & gap



Cylindrical standard sensors (socket)

capaNCDT CSx /CS-x



Model		CS005	CS02	CS08
Measuring range	Reduced	0.025 mm	0.1 mm	0.4 mm
	Nominal	0.05 mm	0.2 mm	0.8 mm
	Extended	0.1 mm	0.4 mm	1.6 mm
Resolution ^[1]	Static	0.015 nm	0.06 nm	0.24 nm
	Dynamic	1 nm	4 nm	16 nm
Linearity ^[2]		< ±0.2 μm	< ±0.4 μm	< ±0.24 μm
Replacement accuracy ^[3]		< ±0.5 % FSO	< ±0.3 % FSO	< ±0.3 % FSO
Temperature stability ^[4]		-0.01 μm / K	-0.01 μm / K	-0.03 μm / K
Recommended target size (flat) ^[5]		Ø 3 mm	Ø 5 mm	Ø 9 mm
Active measuring area		Ø 1.3 mm	Ø 2.6 mm	Ø 4.9 mm
Connection ^[6]		Plug connection via triaxial socket (type C)		
Temperature range	Storage	-50 ... 200 °C		
	Operation	-50 ... 200 °C		
Shock (DIN EN 60068-2-27)		30g / 5 ms in XY axis, 1000 shocks each		
Vibration (DIN EN 60068-2-6)		20 g / 58 ... 2000 Hz in XY axis, 10 cycles each		
Protection class (DIN EN 60529)		IP40		
Material		NiFe (magn.)		
Weight		approx. 2 g	approx. 2 g	approx. 7 g
Mounting		Circumferential clamping		
Recommended mounting position ^[7]		3 mm		
Compatibility		Compatible with all capacitive controllers from Micro-Epsilon Sensors can be replaced as required without recalibration (see replacement accuracy)		

^[1] RMS noise referred to the end of the measuring range and to the nominal measuring range using the standard cable CCm (1.4 m); valid for operation with the DT6530: static 2 Hz, dynamic 8.5 kHz

^[2] Typical linearity that must be added to the controller linearity; applies to standard cable tuning CCm (1.4 m)

^[3] FSO = Full Scale Output | The value corresponds to the slope error that occurs when a sensor is replaced without recalibration

^[4] In recommended mounting position; from a temperature of +150 °C: non-linear signal drift

^[5] In relation to the nominal measuring range

^[6] For suitable sensor cables, please refer to Connections

^[7] From the sensor front face (measuring surface), opposite to the measuring direction

Mounting the cylindrical sensors CSx and CS-x

CSx / CS-x cylindrical sensors can be installed either protruding (with the sensor extending beyond the mounting bracket) or flush with the mounting bracket. The sensor is mounted either by point clamping using a plastic set screw or by circumferential clamping using a collet. When using circumferential clamps, please note that the surrounding material may cause heat buildup. CS-x series sensors with measuring ranges of ≤ 2 mm have a mechanically defined clamping point (slightly wider housing).

The technical specifications always refer to circumferential clamping at the recommended mounting position.

Recommended mounting of CSx sensors



With set screw

With circumferential clamping



Model		CS-0,25/C	CS-0,5/C	CS-1/B	CS-2/B	CS-3/B	CS-5/B	CS-10/B
Measuring range	Reduced	0.125 mm	0.25 mm	0.5 mm	1 mm	1.5 mm	2.5 mm	5 mm
	Nominal	0.25 mm	0.5 mm	1 mm	2 mm	3 mm	5 mm	10 mm
	Extended	0.5 mm	1 mm	2 mm	4 mm	6 mm	10 mm	20 mm
Resolution ^[1]	Static	0.075 nm	0.15 nm	0.3 nm	0.6 nm	0.9 nm	1.5 nm	3 nm
	Dynamic	5 nm	10 nm	20 nm	40 nm	60 nm	100 nm	200 nm
Linearity ^[2]		< ±0.125 μm	< ±0.15 μm	< ±1 μm	< ±0.4 μm	< ±0.6 μm	< ±1 μm	< ±15 μm
Temperature stability ^[3]		-0.015 μm/K	-0.025 μm/K	-0.035 μm/K	-0.13 μm/K	-0.3 μm/K	-0.35 μm/K	-0.5 μm/K
Recommended target size (flat) ^[4]		Ø 5 mm	Ø 7 mm	Ø 9 mm	Ø 17 mm	Ø 27 mm	Ø 37 mm	Ø 57 mm
Connection		Plug connection via triaxial socket (type C)			Plug connection via triaxial socket (type B)			
Temperature range	Storage	-50 ... 200 °C						
	Operation	-50 ... 200 °C						
Humidity		0 % RH ... 95 % RH (non-condensing)						
Shock (DIN EN 60068-2-27)		50 g / 5 ms in 6 directions, 1000 shocks each						
Vibration (DIN EN 60068-2-6)		30 g / 10 ... 2000 Hz in 3 axes 2.5 mm, 10 cycles each						
Protection class (DIN EN 60529)		IP40						
Material		NiFe (magn.)			1.4404 (non-magn.)			
Weight		approx. 1.8 g	approx. 3.6 g	approx. 7.7 g	approx. 45.6 g	approx. 64.2 g	approx. 91.3 g	approx. 179.1 g
Mounting		Circumferential clamping						
Recommended mounting position		at the defined clamping range (marking on the sensor)				on the mandrel (Ø 20 mm); 7.5 mm behind the sensor face		
Compatibility		Compatible with all capacitive controllers from Micro-Epsilon Sensors can be replaced as required without recalibration (see replacement accuracy)						

^[1] RMS noise referred to the end of the measuring range and to the nominal measuring range using the standard cable CCm (1.4 m); valid for operation with the DT6530: static 2 Hz, dynamic 8.5 kHz
^[2] Typical linearity that must be added to the controller linearity; applies to standard cable tuning CCm (1.4 m)
^[3] In recommended mounting position; from a temperature of +150 °C: non-linear signal drift
^[4] In relation to the nominal measuring range

Recommended mounting of CS-x sensors

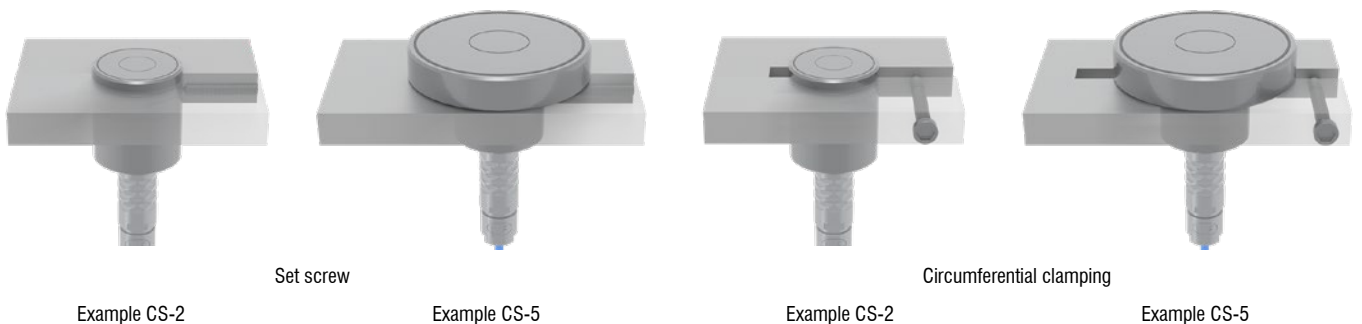

Dimensions

capaNCDT CSx /CS-x

CS005

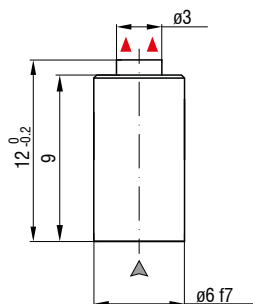

CS02

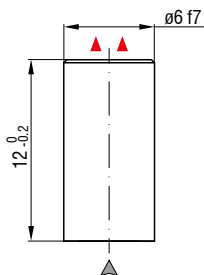

CS08

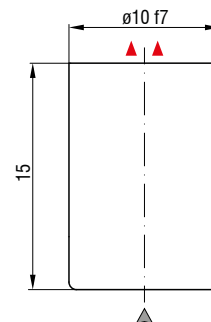

CS-0,25/C

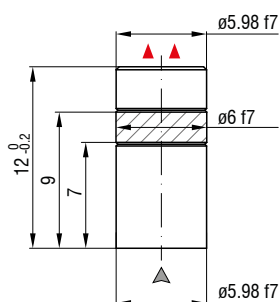

CS-0,5/C

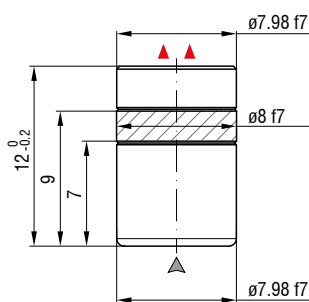

CS-1/B

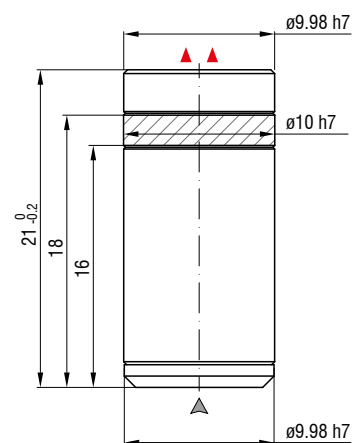

CS-2/B

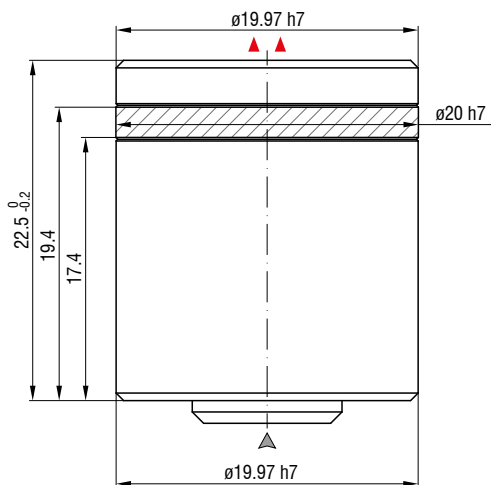

CS-3/B

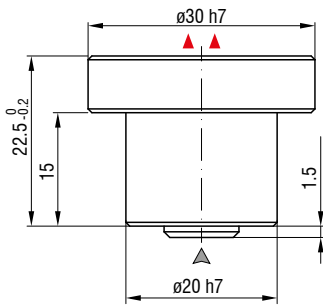

CS-5/B

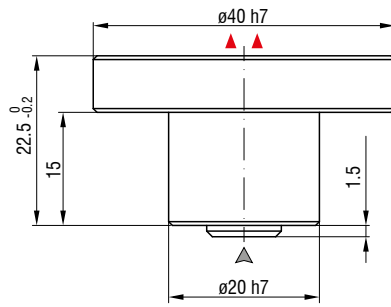

CS-10/B

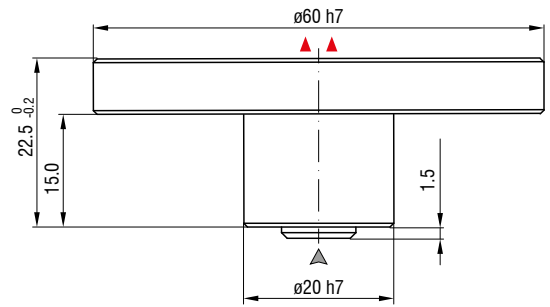

▲ ▲ Measurement direction

▲ Connector side

(dimensions in mm, not to scale)

High-precision cylindrical sensors (integrated cable)

capaNCDT CSH



Model		CSH02-CAm1,4	CSH05-CAm1,4	CSH1-CAm1,4	CSH1,2-CAm1,4	CSH2-CAm1,4
Measuring range	Reduced	0.1 mm	0.25 mm	0.5 mm	0.6 mm	1 mm
	Nominal	0.2 mm	0.5 mm	1 mm	1.2 mm	2 mm
	Extended	0.4 mm	1 mm	2 mm	2.4 mm	4 mm
Resolution ^[1]	Static	0.06 nm	0.15 nm	0.3 nm	0.36 nm	0.6 nm
	Dynamic	4 nm	10 nm	20 nm	24 nm	40 nm
Linearity ^[2]		< ±0.08 μm	< ±0.35 μm	< ±0.6 μm	< ±1.2 μm	< ±0.6 μm
Replacement accuracy ^[3]		< ±0.5 % FSO	< ±0.2 % FSO	< ±0.2 % FSO	< ±0.2 % FSO	< ±0.2 % FSO
Temperature stability ^[4]		-0.01 μm / K	+0.01 μm / K	+0.056 μm / K	+0.052 μm / K	+0.152 μm / K
Recommended target size (flat) ^[5]		Ø 7 mm	Ø 7 mm	Ø 11 mm	Ø 11 mm	Ø 17 mm
Active measuring area		Ø 2.6 mm	Ø 4.1 mm	Ø 5.7 mm	Ø 6.3 mm	Ø 8.1 mm
Connection		integrated cable with connector (type B); standard length 1.4 m				
Mounting		Circumferential clamping				
Temperature range	Storage	-50 ... 200 °C				
	Operation	-50 ... 200 °C				
Shock (DIN EN 60068-2-27)		30g / 5 ms in XY axis, 1000 shocks each				
Vibration (DIN EN 60068-2-6)		20 g / 58 ... 2000 Hz in XY axis, 10 cycles each				
Protection class (DIN EN 60529)		IP40				
Material		1.4104 (magn.)				
Weight		approx. 30 g (incl. cable)	approx. 30 g (incl. cable)	approx. 33 g (incl. cable)	approx. 33 g (incl. cable)	approx. 38 g (incl. cable)
Recommended mounting position ^[6]		3 mm				
Compatibility		Compatible with all capacitive controllers from Micro-Epsilon Sensors can be replaced as required without recalibration (see replacement accuracy)				

^[1] RMS noise referred to the end of the measuring range and to the nominal measuring range using the standard cable CCm (1.4 m); valid for operation with the DT6530: static 2 Hz, dynamic 8.5 kHz

^[2] Typical linearity to be added to the controller linearity; valid for standard cable adjustment CCm (1.4 m)

^[3] FSO = Full Scale Output | The value corresponds to the slope error that occurs when a sensor is replaced without recalibration

^[4] In recommended mounting position; from a temperature of +120 °C: non-linear signal drift

^[5] In relation to the nominal measuring range

^[6] From the sensor front face (measuring surface), opposite to the measuring direction

Mounting of cylindrical CSH sensors

CSH-type cylindrical sensors can be installed either protruding (with the sensor extending beyond the mounting bracket) or flush with the mounting bracket. The sensor is mounted either by point clamping using a plastic set screw or by circumferential clamping using a collet. When using circumferential clamps, please note that the surrounding material may cause heat buildup.

The technical specifications always refer to circumferential clamping at the recommended mounting position.

Recommended mounting of CSH sensors



With set screw

With circumferential clamping

CSH02-CAm1,4

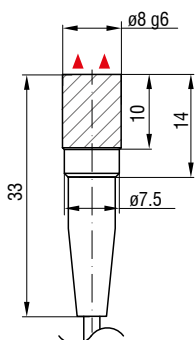

CSH05-CAm1,4

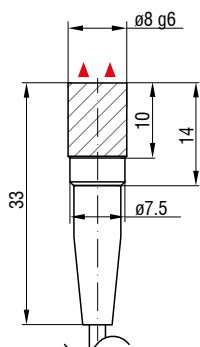

CSH1-CAm1,4

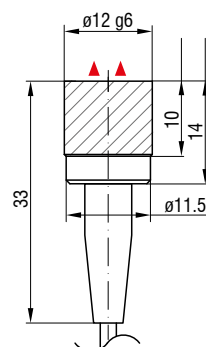

CSH1,2-CAm1,4

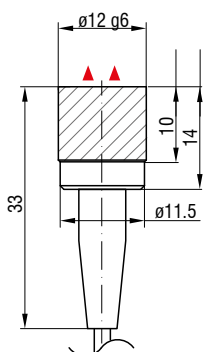

CSH2-CAm1,4

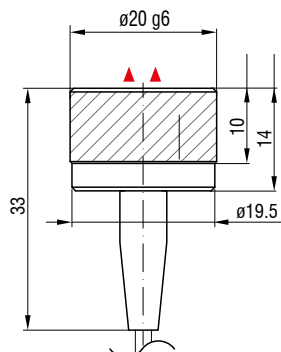

▲ ▲ Measurement direction

(dimensions in mm, not to scale)

Dimensions

capa^{NC}DT CSF

Flat sensors with integrated sensor cable

CSF2-CRg4.0

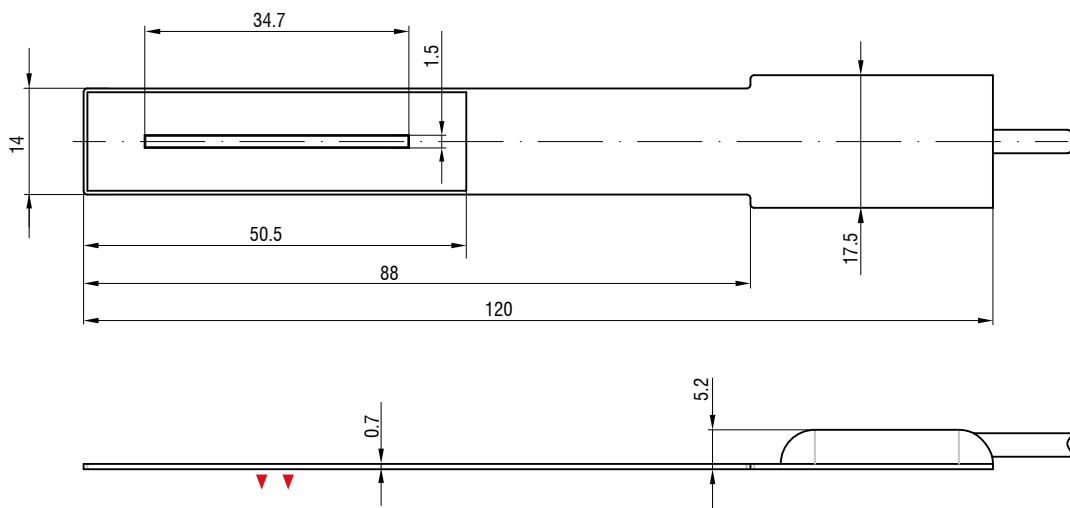

CSF4-CRg4.0

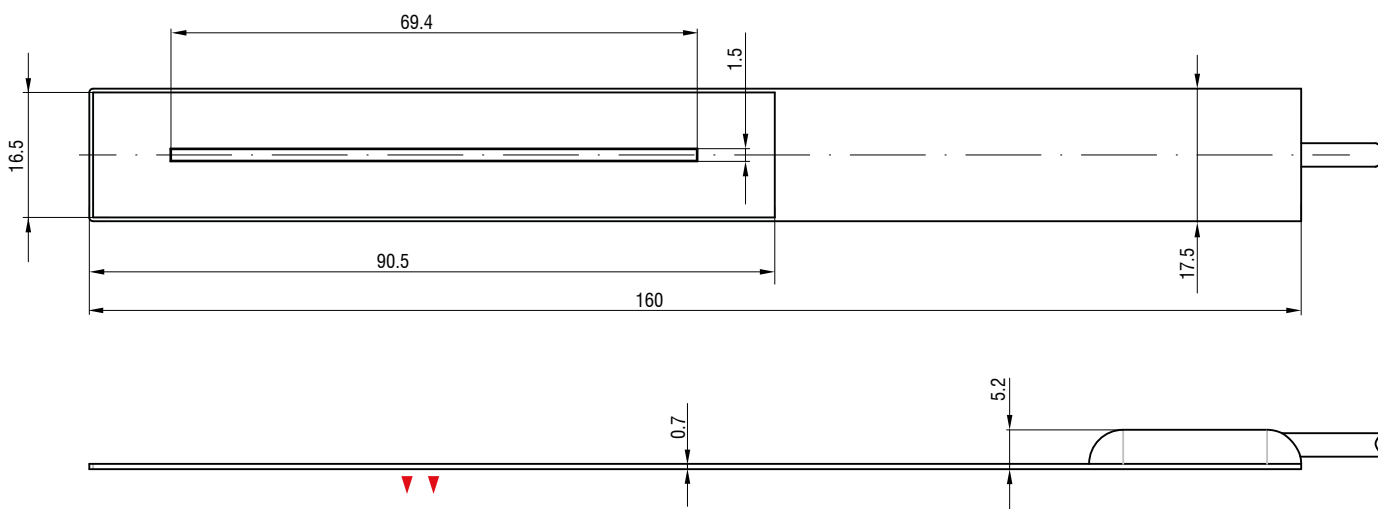

CSF6-CRg4.0

