

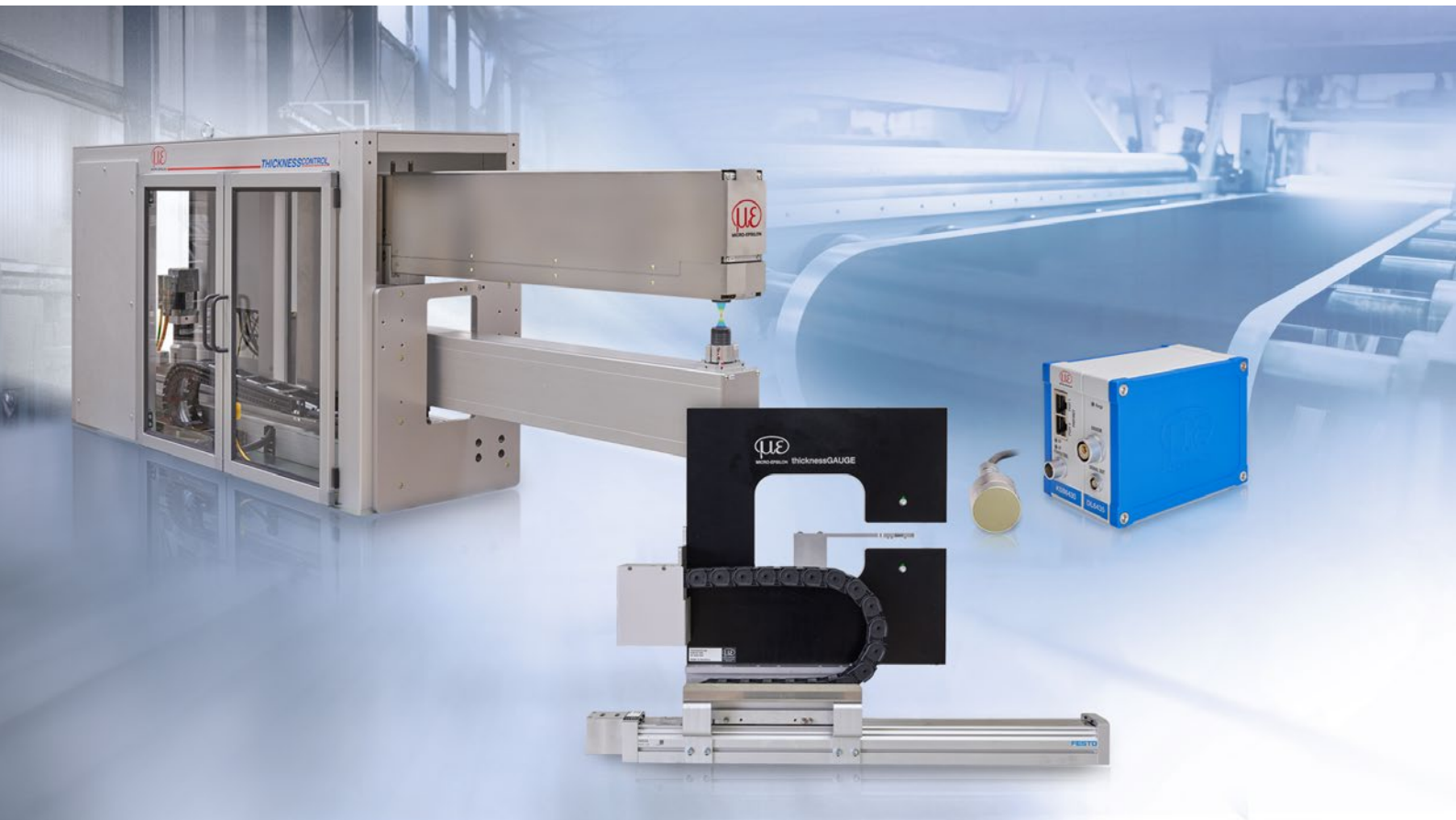

More Precision

Sensor systems for battery film production

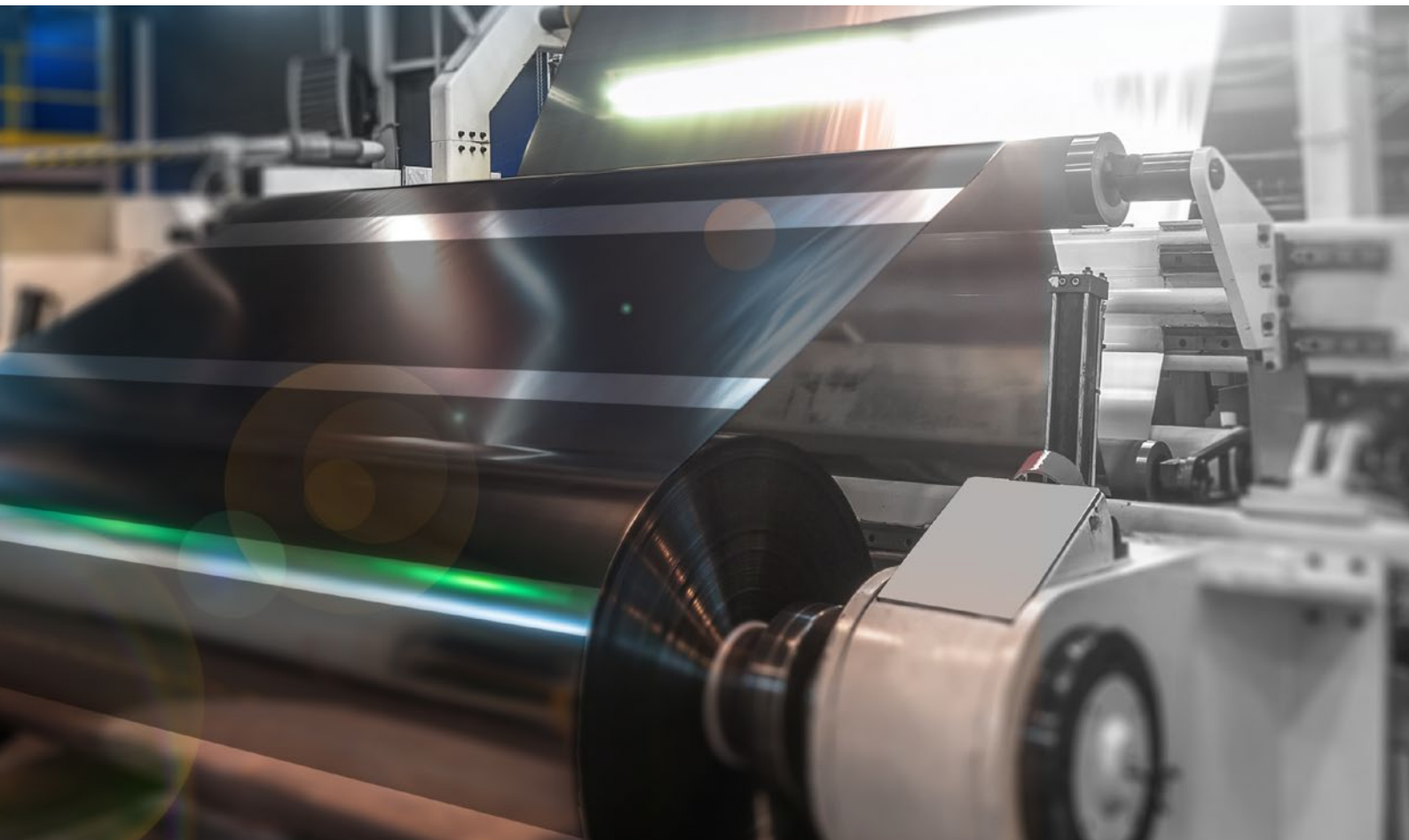



Overview

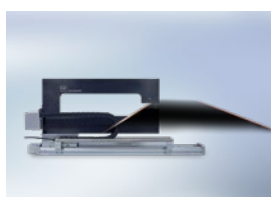

Turnkey sensor system
for thickness measurement
thicknessGAUGE C.C

Page 4 - 5

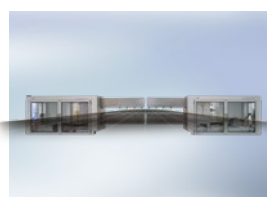

Robust system for
thickness measurement
(up to 8 measurement tracks)
thicknessCONTROL BTG 8702 2C.C

Page 10 - 11

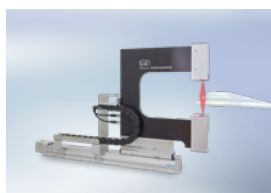

Turnkey sensor system for thickness
measurement and 3D measurement
thicknessGAUGE 3D

Page 6 - 7

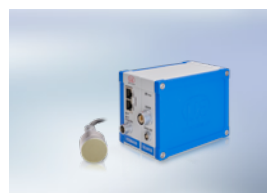

Sensor system for precise
thickness measurement of coatings
combiSENSOR

Page 12 - 13

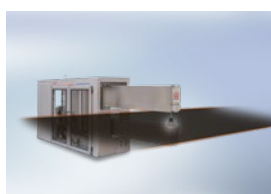

Robust system for
thickness measurement
(up to 5 measurement tracks)
thicknessCONTROL BTG 8702 C.C

Page 8 - 9



Offline measuring system for
thickness measurement of thin film
capaNCDT TFG6220

Page 14 - 15

Inline thickness measurement of battery film and electrode material

The precise measuring systems from Micro-Epsilon are used for inline thickness measurement. The tried-and-tested systems are equipped with high-resolution sensors and increase process stability, production speed and quality in modern coating lines.

These turnkey measuring systems are used in numerous strip and sheet processes. A linear unit with electromechanical drive enables thickness measurements in traversing mode. Alternatively, fixed track measurements are possible for center-line measurements (center thickness) or for thickness measurements on the edges.

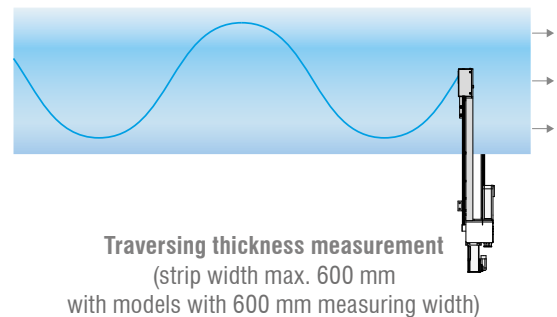
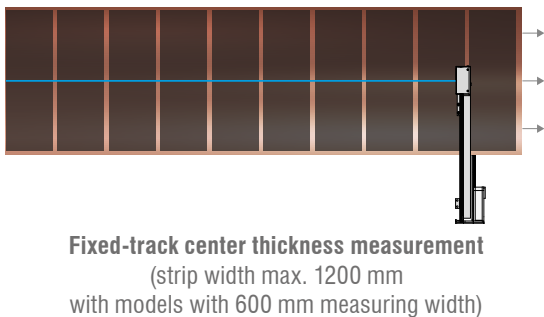
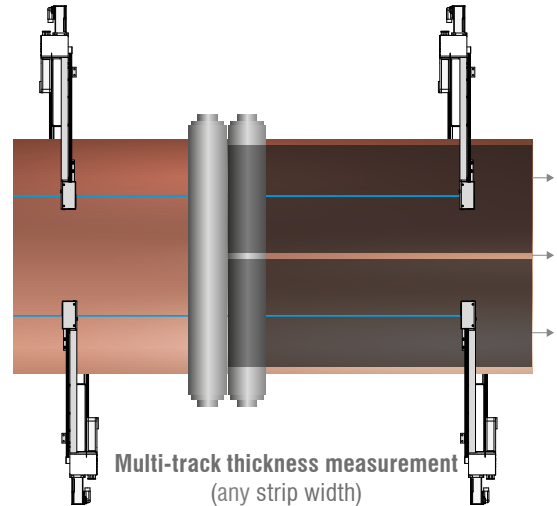
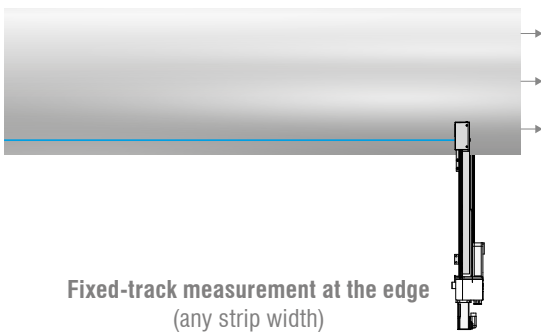

Powerful analysis and control software

The systems include a multi-touch-capable industrial PC with a comprehensive software package. This allows production data to be displayed, monitored, analyzed and archived.

Software features:

- Article database
- Production archive
- Statistical evaluations
- Limit value monitoring with feedback to production
- Fieldbus interfaces (optional)
- Verification of gauge/test equipment capability

Sensor system for precise thickness measurement (confocal chromatic sensors) thicknessGAUGE C.C

Sensors used:
Confocal chromatic displacement sensors

Measurement with white light, no safety precautions required

Thickness measuring range: 2.5 mm

Accuracy: $\pm 0.4 \mu\text{m}$

Measuring rate: up to 10 kHz

Precise thickness measurement on mirroring and shiny surfaces



Thickness measurement with high precision

The thicknessGAUGE sensor systems are used for precise thickness measurement of strip materials, plates and sheets. Several models with different measuring ranges and measuring widths enable the inline thickness measurement of different materials and surfaces. For example, the thicknessGAUGE systems are used to measure the thickness of coated electrode film.

This fully assembled system comprises a stable frame on which two confocal distance sensors are fixed which detect the thickness of the measuring object according to the difference principle. The high-performance sensors achieve precise measurement results at a high measuring rate.

The sensors are perfectly aligned to each other and calibrated during the assembly. Furthermore, thickness calibration at the factory ensures high precision.

Compact complete system for easy integration

These compact systems are comprised of an integrated linear unit including motor control, a compact bus terminal box, an automatic calibration unit as well as a multi-touch PC with pre-installed software. The entire system is powered via a 24 V source.

Examples of customized modifications:

- Selectable cable lengths
- Customer-specific axis length
- Encoder
- Interface for fieldbus connection
- Digital inputs/outputs

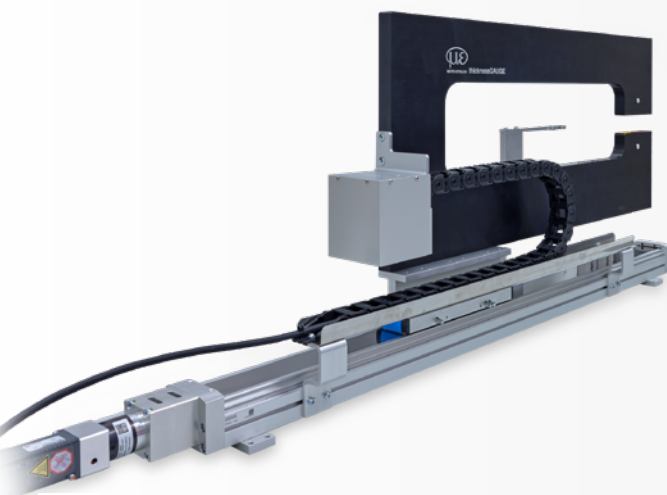

Linear axis for high flexibility

The thicknessGAUGE sensor systems are equipped with a linear axis. A measurement standard for fully automatic calibration is in the parking position. The electromechanical drive can be used in traversing or fixed-track mode.

Automatic calibration & temperature compensation

To compensate for temperature-related effects, the thicknessGAUGE systems are equipped with an in-situ calibration, which is carried out in the parking position. Calibration is performed automatically and at freely selectable intervals. In addition to temperature compensation, in-situ calibration enables proper functioning of the system.

Model		C.C-2.5/200	C.C-2.5/400	C.C-2.5/600
Article number		4350127.920	4350127.921	4350127.922
Measuring width		200 mm	400 mm	600 mm
Operating range			32 mm	
Measuring range			2.5 mm	
Max. travel path ^[1]		380 mm	580 mm	780 mm
System accuracy ^[2]			±0.4 µm	
Resolution			40 nm	
Measuring rate			max. 10 kHz	
Calibration			Automatic	
Weight	Axis, motor and C-frame	19.8 kg	24.3 kg	28.4 kg
	Bus terminal box and panel IPC		15.9 kg	
Supply voltage			24 V	
Humidity			5 % RH ... 95 % RH (non-condensing)	
Protection class (DIN EN 60529)			IP40 (bus terminal box IP54)	
Temperature range	Storage		-20 ... 65 °C	
	Operation		5 ... 45 °C ^[3]	
Control and display elements		Panel-IPC with thicknessCONTROL software included in the scope of supply		
Special features		Compact bus terminal box measuring just 300 x 400 x 210 mm		

^[1] Other lengths on request

^[2] 2 Sigma; data valid for high-gloss, metallic measuring standard (DAkkS certified)

^[3] The temperature range for bus terminal boxes is limited to 5 ... 40 °C

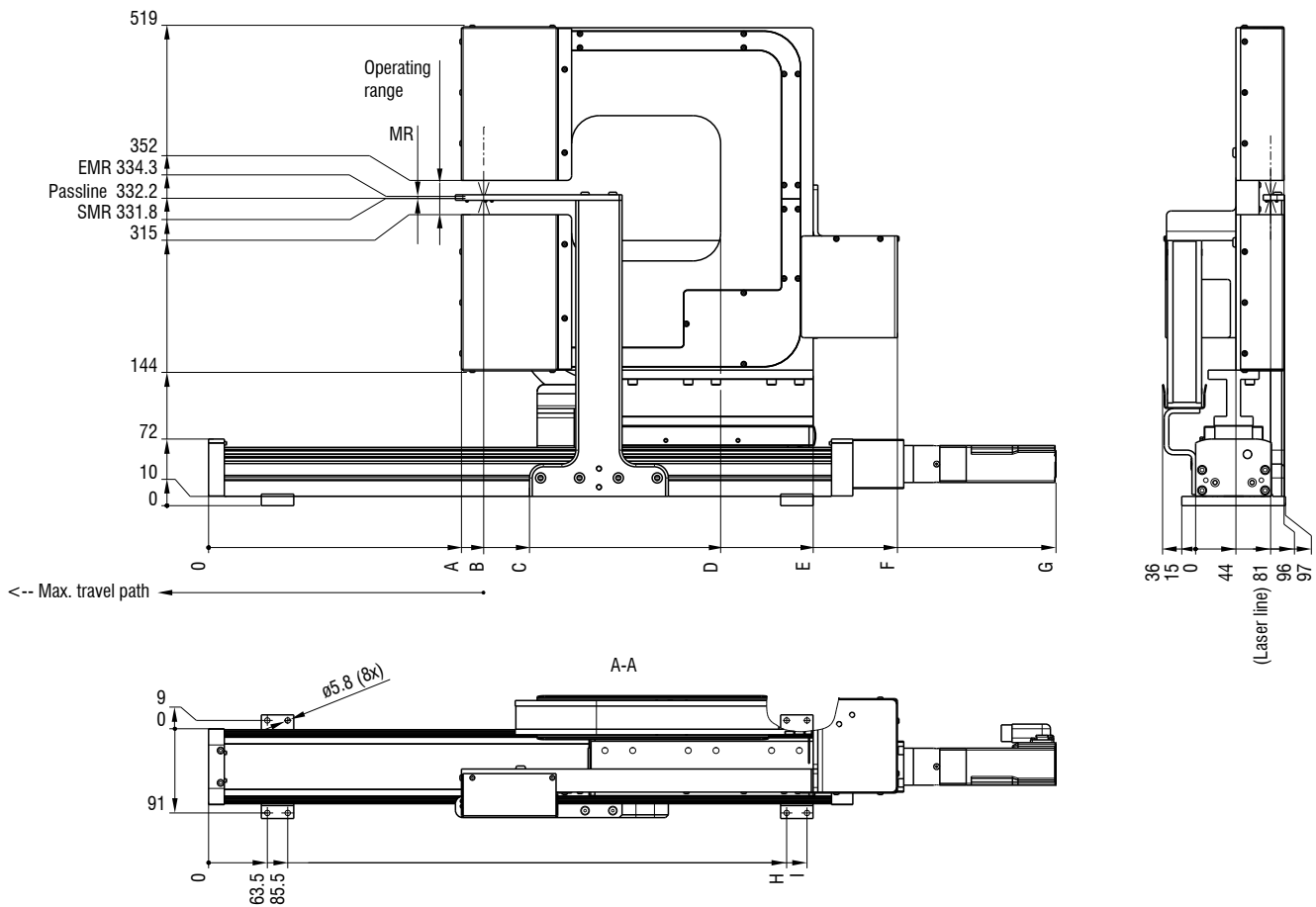

Dimensions in mm, not to scale.

Sensor system for precise inline thickness and profile measurements

thicknessGAUGE 3D

Compact complete solution with 24V-supply

For many types of surfaces / materials

Traverses via linear axis

Fully automatic calibration

Integrated software

Laser class 2M, no special safety precautions required



Inline thickness and profile measurements

The thicknessGAUGE 3D is a precise sensor system for two-sided profile and thickness measurements of sheets and extrusion materials. Two opposing laser profile scanners detect synchronized profile data along a linear movement, which is merged into a 3D point cloud. The thicknessCONTROL 3D uses this point cloud to calculate freely programmable target values in order to solve complex 2D or 3D measurement tasks.

The specific evaluation is parameterized using the 3DInspect software, where the measurement programs and parameters are transferred to the thicknessCONTROL software and processed automatically.

Ultimately, only the desired result is output. A linear axis moves the sensor system from the parking position to the measuring position. A measurement standard for fully automatic calibration is in the parking position.

Automatic calibration and temperature compensation

The thicknessGAUGE systems are equipped with an in-situ calibration, e.g. to compensate for temperature-related effects. A linear axis moves the thicknessGAUGE to the parking position. The calibration cycles are individually adjustable. In addition to temperature compensation, in-situ calibration enables proper functioning of the system to be verified cyclically and at any time.



Fully automatic calibration enables reliable measurements

Example of measured data:

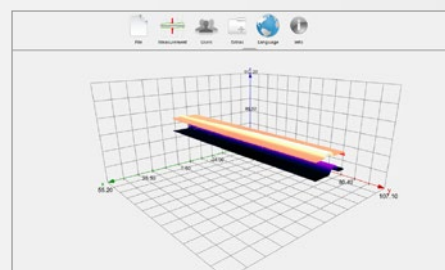
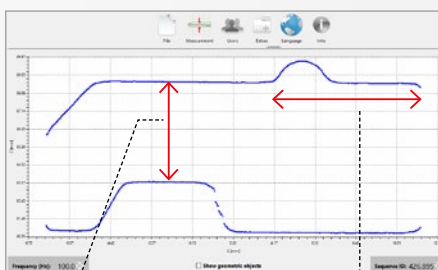
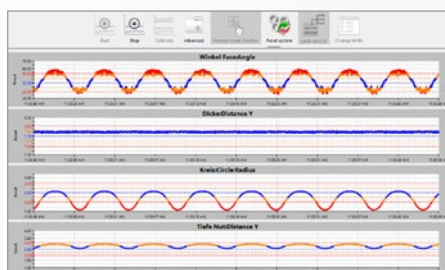

Thickness calculation possible Profile evaluation possible

Modell	C.LP-3D-15/200	C.LP-3D-15/400	C.LP-3D-15/600	
Article number	4350127.730	4350127.731	4350127.732	
Measuring width	200 mm	400 mm	600 mm	
Operating range		144 mm		
Measuring range ^[1]	Z-axis (thickness)	15 mm		
	X-axis (3D measurement)		max. 26.8 mm	
Max. travel path ^[2]	380 mm	580 mm	780 mm	
System accuracy ^[3]		±1.2 µm		
Resolution	Z-axis (thickness)	0.2 µm		
	X-axis (3D measurement) ^[4]		1,024 points/profile	
Measuring rate ^{[1] [5]}		500 Hz		
Calibration		Automatic		
Weight	Axis, motor and C-frame	17.6 kg	22.3 kg	26.8 kg
	Bus terminal box and panel IPC		14.1 kg	
Supply voltage		24 V		
Humidity		5 % RH ... 95 % RH (non-condensing)		
Protection class (DIN EN 60529)		IP40 (bus terminal box IP54)		
Temperature range	Storage	-20 ... 65 °C		
	Operation	5 ... 45 °C		
Control and indicator elements		Panel IPC with software included in the scope of supply		
Special features		Compact bus terminal box measuring just 300 x 300 x 210 mm		

^[1] Depending on the measurement task

^[2] Other lengths on request

^[3] 2 Sigma; data valid for diffusely reflecting, metallic measuring standard (DAkkS certified)

^[4] 1,024 points/profile (standard); 2,048 points/profile on request

^[5] 500 Hz (standard); up to 2000 Hz on request

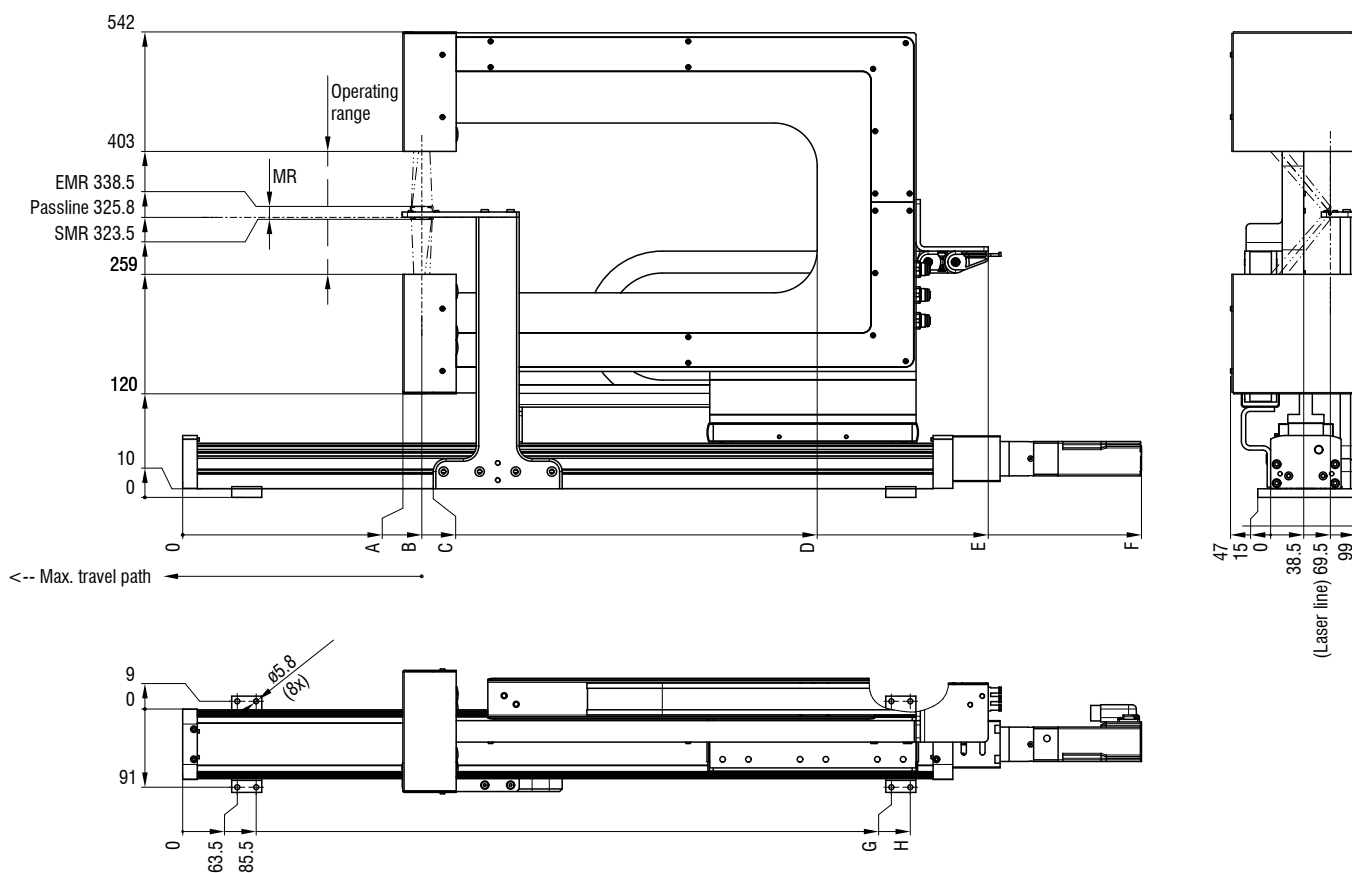

Model	A	B	C	D	E	F	G	H
C.LP-3D-15/200	271	293.2	307	563	737	916	624.5	646.5
C.LP-3D-15/400	256	278	292	738	937	1115	824.5	846.5
C.LP-3D-15/600	224	245.5	259	916	1140	1316	1024.5	1046.5

MR = Measuring range
SMR = Start of measuring range
EMR = End of measuring range
Dimensions in mm, not to scale.

High precision thickness measuring system for coated anode and cathode film **thicknessCONTROL BTG 8702 C.C**

High-precision thickness measurement
in up to 5 measurement tracks

Ideal for fast strip processes

High temperature stability enables use in
dry/calendering applications

Robust design with protective housing



High-precision inline thickness measurement of battery film

For high-precision inline thickness measurement of coated electrode film in lithium-ion battery cell production, Micro-Epsilon offers the thicknessCONTROL BTG, a metrologically sophisticated system based on confocal chromatic sensor technology.

The system consists of a C-frame with up to five precisely adjusted sensor pairs, which enable the film thickness to be detected synchronously on both sides in up to five measurement tracks. This allows continuous profiling of the layer thickness across the entire strip width with high lateral resolution.

The confocal chromatic sensors used are characterized by a high axial resolution in the submicrometer range and low sensitivity to spectral reflections.

This makes the system particularly suitable for complex, reflective or inhomogeneous surfaces such as graphite or lithium-metal coated substrates. The system is designed for production speeds of up to several hundred m/min and offers immediate feedback to higher-level process controls due to the real-time capability of the signal processing.

The integrated temperature compensation based on internal sensors and FEM-optimized frame geometries ensures high measurement stability even under thermal loads such as those typically found in the drying or calendering zone. Thanks to its open architecture and standardized interfaces (e.g. PROFINET, EtherCAT, OPC UA), the thicknessCONTROL BTG can be seamlessly integrated into existing MES or SCADA

systems. The supplied analysis software enables detailed trend analyses, tolerance monitoring and control parameterization to minimize material waste and process deviations.

The system is used for high-precision inline thickness measurement of coated anode and cathode film in battery production. It impresses with long-term stable and drift-free measurements that ensure consistently high product quality. Especially in the production of lithium-ion batteries, where the smallest fluctuations in layer thickness can affect the performance and safety of the cell, the accuracy of the measurement plays a central role.

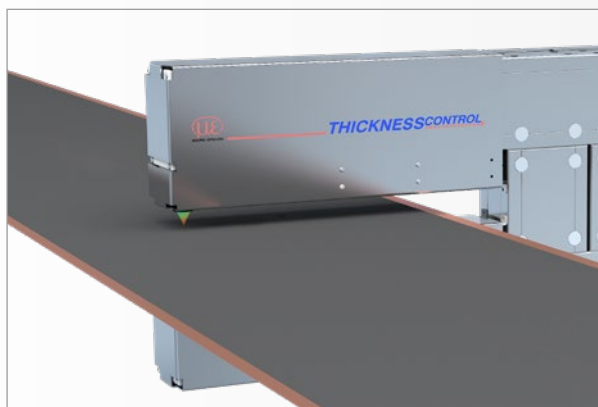

High precision in fast strip processes

The thicknessCONTROL BTG systems measure the thickness of coated battery film with high accuracy. Due to the high measuring rate, production speeds of several hundred m/min can be monitored. The C-frames can be equipped with up to 5 pairs of sensors.

Model	BTG 8702 C.C - 3/500	BTG 8702 C.C - 6/500	BTG 8702 C.C - 3/800	BTG 8702 C.C - 6/800
Article number	4350127.655	4350127.650	4350127.658	4350127.653
Measuring width	500 mm	500 mm	800 mm	800 mm
Operating range	43 mm	63 mm	43 mm	63 mm
Measuring range	3.6 mm	7 mm	3.6 mm	7 mm
System accuracy ^[1]	$\pm 0.3 \mu\text{m}$	$\pm 0.5 \mu\text{m}$	$\pm 0.3 \mu\text{m}$	$\pm 0.5 \mu\text{m}$
Resolution	15 nm	20 nm	15 nm	20 nm
Calibration	Automatic			
Humidity	5 % RH ... 95 % RH (non-condensing)			
Protection class	IP54			
Temperature range	Storage	-20 ... 65 °C		
	Operation	5 ... 35 °C		
Control and display elements	Rittal control cabinet incl. panel PC with thicknessCONTROL software included in the scope of delivery			
Special features	Protective housing			

^[1] 2 Sigma; data valid for highly reflective, metallic measuring standard (DAkkS certified)

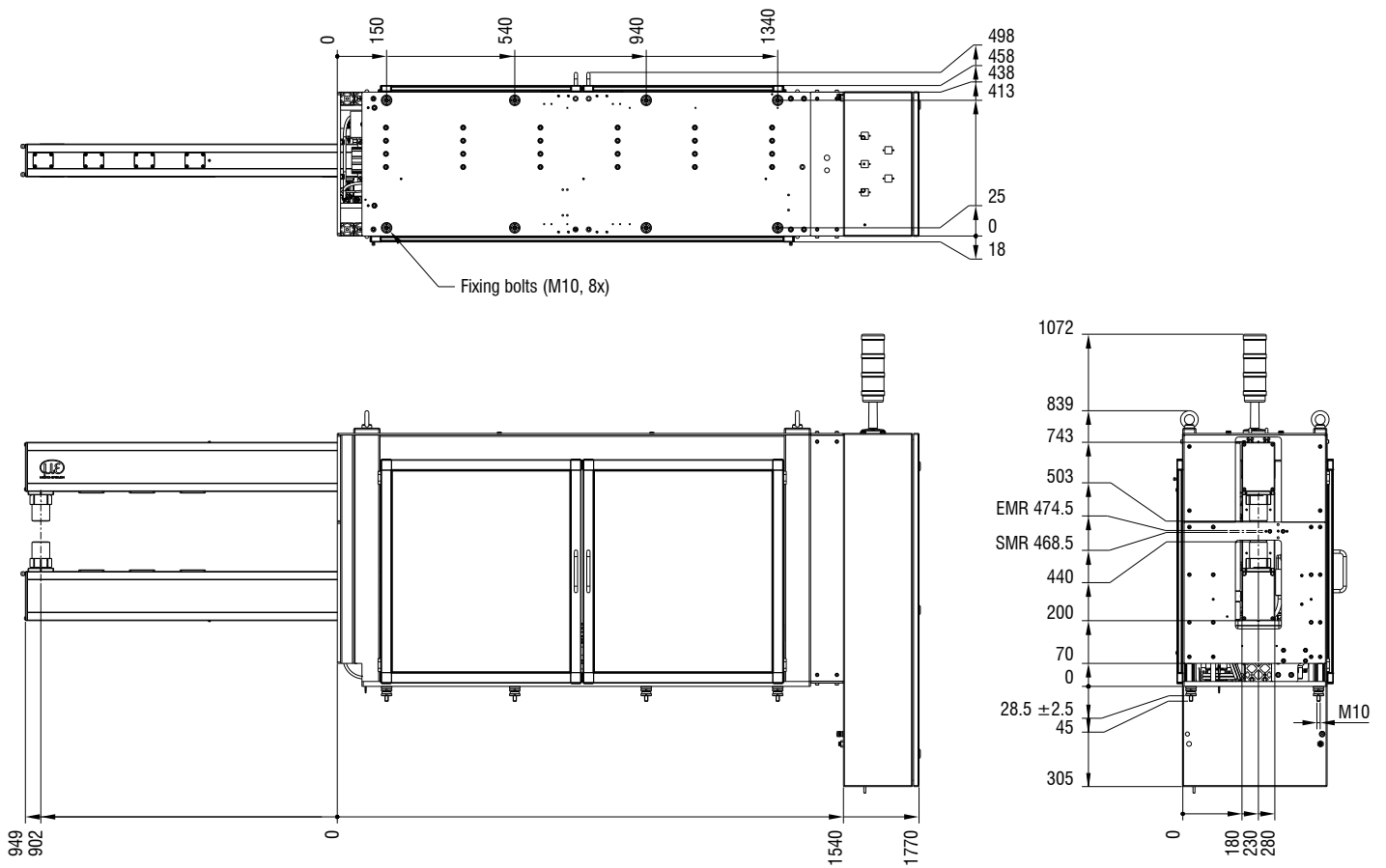

Dimensions in mm, not to scale.

High precision thickness measuring system for coated anode and cathode film **thicknessCONTROL BTG 8702 2C.C**

High-precision thickness measurement

Ideal for fast strip processes

High temperature stability enables use in dry/calendering applications

Multi-track version:
up to 8 sensor pairs on 2 C-frames

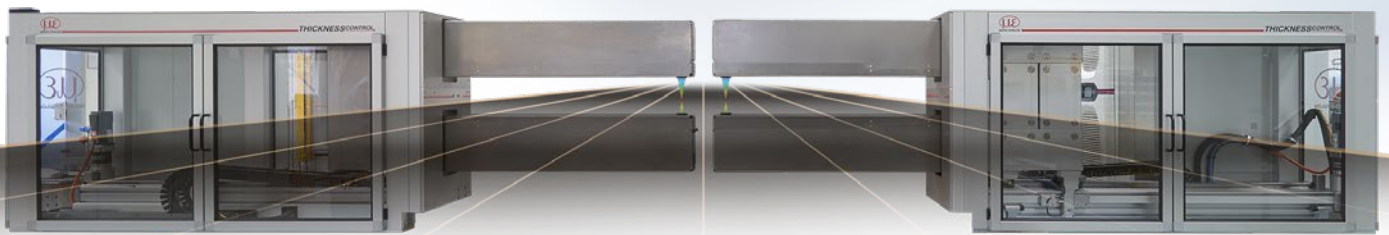

High-precision inline thickness measurement of wide battery film

For precise inline thickness measurement of coated electrode film in the production of lithium-ion battery cells, Micro-Epsilon offers the thicknessCONTROL BTG 2C.C, a highly developed measuring system for material widths of over 1000 mm.

The system consists of two C-frames, each equipped with up to four precisely aligned pairs of sensors. These enable the synchronous, double-sided detection of the film thickness in up to eight parallel measurement tracks. This allows a continuous thickness profile to be detected across wide strips with high lateral resolution.

The confocal chromatic sensors used offer an axial resolution in the submicrometer

range and are particularly insensitive to spectral reflections. This makes the system ideal for measuring complex, reflective or inhomogeneous surfaces such as graphite or lithium metal-coated substrates.

Designed for production speeds of several hundred meters per minute, the system provides immediate feedback to higher-level process controls due to real-time signal processing. Integrated temperature compensation, supported by internal sensors and FEM-optimized frame geometries, ensures high measurement stability even under thermal influences such as those typically found in drying or calendering zones.

Due to its open system architecture and standardized interfaces such as PROFINET, EtherCAT or OPC UA, the thicknessCONTROL

BTG 2C.C can be easily integrated into existing MES or SCADA environments. The associated analysis software supports comprehensive trend analyses, tolerance monitoring and the parameterization of control loops to optimize the use of materials and stabilize the process.

The system is primarily used for precise inline thickness measurement of coated anode and cathode film in battery production. It impresses with long-term stable, drift-free measurement results and thus ensures consistently high product quality. Precise measurement is particularly important in the production of lithium-ion batteries, where minimal deviations in layer thickness affect the performance and safety of the cells.



High precision for multi-track thickness measurement

The thicknessCONTROL BTG 2C.C systems measure the thickness of coated battery film with high accuracy. Up to four pairs of sensors on two C-frames enable thickness measurement on large strips. Thanks to the high measuring rate, production speeds of several hundred m/min can be monitored.

Model	BTG 8702 2C.C - 3/1000	BTG 8702 2C.C - 6/1000	BTG 8702 C.C - 3/1600	BTG 8702 C.C - 6/1600
Article number	4350127.656	4350127.651	4350127.659	4350127.654
Measuring width	1000 mm	1000 mm	1600 mm	1600 mm
Operating range	43 mm	63 mm	43 mm	63 mm
Measuring range	3.6 mm	7 mm	3.6 mm	7 mm
System accuracy ^[1]	±0.3 μm	±0.5 μm	±0.3 μm	±0.5 μm
Resolution	15 nm	20 nm	15 nm	20 nm
Calibration	Automatic			
Supply voltage	24 V (230 V)			
Humidity	5 % RH ... 95 % RH (non-condensing)			
Protection class	IP54			
Temperature range	Storage	-20 ... 65 °C		
	Operation	5 ... 35 °C		
Control and display elements	Rittal control cabinet incl. panel PC with thicknessCONTROL software included in the scope of delivery			
Special features	Protective housing			

^[1] 2 Sigma; data valid for highly reflective, metallic measuring standard (DAkkS certified)

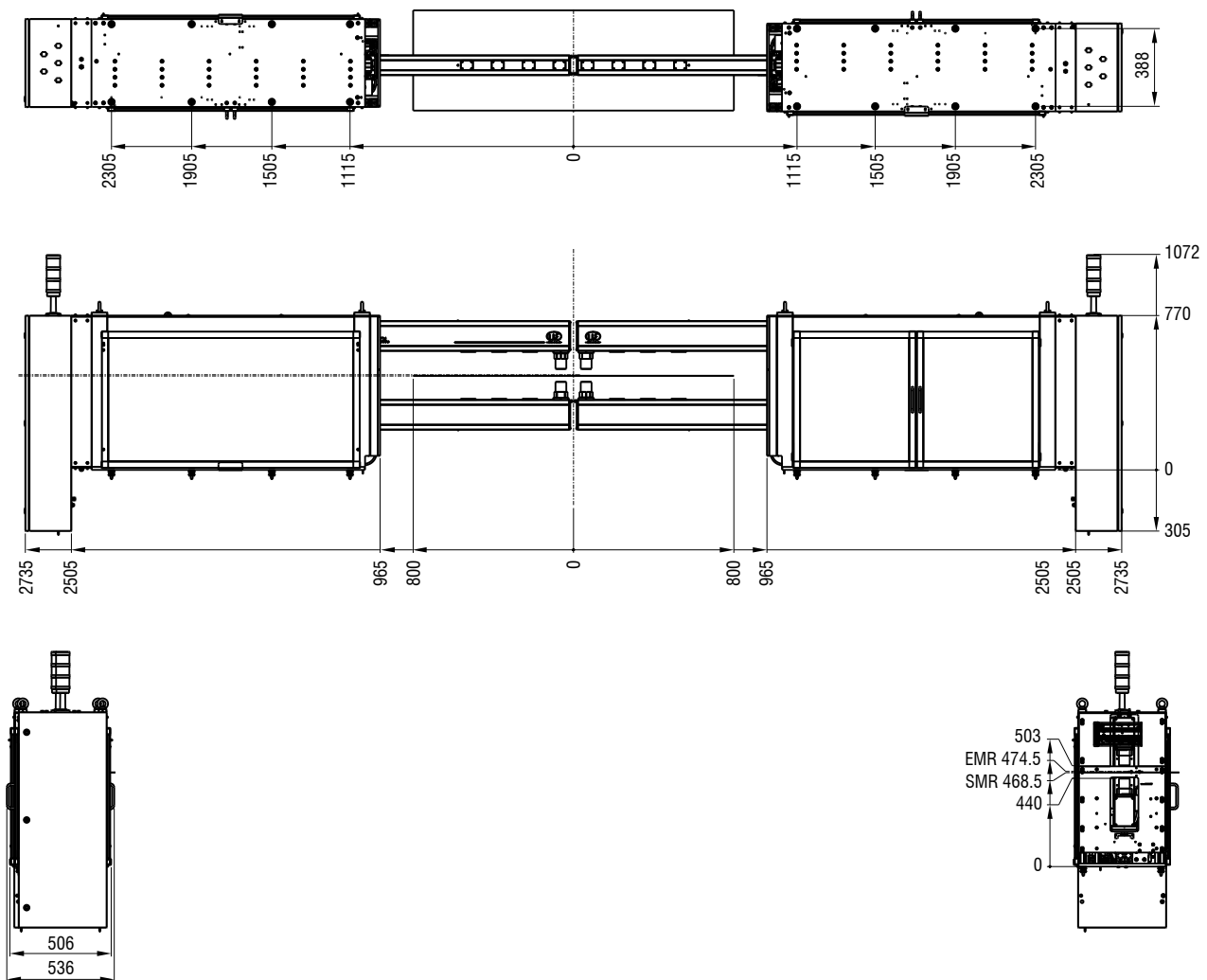

Dimensions in mm, not to scale.

Sensor system for precise one-sided thickness measurement of coatings combiSENSOR KSB6430

Precise thickness measurement of coatings in the calendaring area

Coating thickness from 5 μm to 3 mm

PROFINET / EtherNet/IP, EtherCAT

Extremely high temperature resistance and stability from -10 °C to + 180 °C

Repeatability from 0.5 μm



Sensor system for thickness measurement of electrode coatings

The combiSENSOR KSB combines an eddy current and a capacitive displacement sensor in one housing and enables precise, non-contact thickness measurement of electrode coatings in the dry coating process, which are guided over a steel roller. Its high temperature stability allows for the combiSENSOR to provide constant measurement values even at fluctuating ambient temperatures.

In addition, the sensor is insensitive to soiling which makes it ideal for demanding industrial applications where reliability and precision are crucial factors. This is why the combiSENSOR KSB is often used directly on the calender.

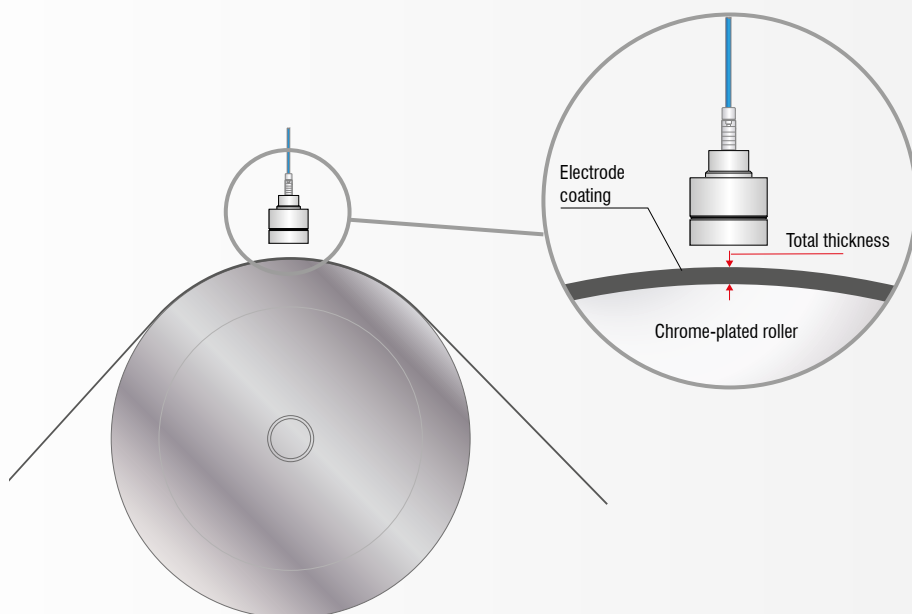

Measuring principle

The combiSENSOR KSB detects the coating thickness with a capacitive sensor to measure the distance from the coating and an eddy current sensor to measure the distance from the chrome-coated steel roller. The difference between the two signals provides the total thickness of the coated film, while mechanical influences are automatically compensated for.

Controller		KSB6430
Model		KSH5 (03)
Insulator thickness (D) ^[1]		5 μm ... 3 mm
Working distance		2 mm ... 5 mm, best performance at 2.5 mm ... 4.0 mm
Resolution ^{[2][3]}	Static (100 Hz)	0.02 μm
	Dynamic (3.9 kHz)	0.075 μm
Repeatability ^[4]		± 0.5 μm
Frequency response (-3dB) ^[5]		1 kHz
Temperature stability ^[6]	Sensor	< 0.25 μm/K
	Controller	< 0.25 μm/K
Supply voltage		12 ... 36 VDC
Power consumption		5.5 W (24 VDC)
Digital interface		EtherCAT / PROFINET / EtherNet
Analog output		0 ... 10 V per value (distance 1, distance 2 and thickness)
Connection		Sensor: pluggable cable via socket; Supply/trigger: 4-pin connector; signal: analog via 4-pin connector, digital via RJ45 connector (see accessories for suitable connection cables)
Mounting	Controller	DIN rail mounting; desktop device
	Sensor	Radial clamping
Temperature range	Storage	Sensor: -10 ... +85 °C; cable: -10 ... +125 °C; controller: 10 ... +75 °C
	Operation	Sensor: -10 ... +180 °C; cable: -10 ... +125 °C; controller: +10 ... +60 °C
Shock (DIN EN 60068-2-27)		15 g / 6 ms in 3 axes, two directions each, 1000 shocks each
Vibration (DIN EN 60068-2-6)		0.75 mm / 10 ... 500 Hz in 3 axes, 2 directions and 10 cycles each 2 g / 10 ... 500 Hz in 3 axes, 2 directions and 10 cycles each
Protection class (DIN EN 60529)		Sensor: IP54; controller: IP40
Weight		Sensor: approx. 80 g, controller: approx. 750 g
Control and indicator elements		3 x color LEDs for range / status

^[1] Insulator thickness below 40 μm on request

^[2] RMS noise relates to mid of measuring range

^[3] Difference signal of the digital output, measured at working distance = 50 % FSO

^[4] Only applies at constant temperature and homogeneous material characteristics of the roller

^[5] Only applies if sampling rate 3900Sa/s is set

^[6] For recommended mounting position

Controller

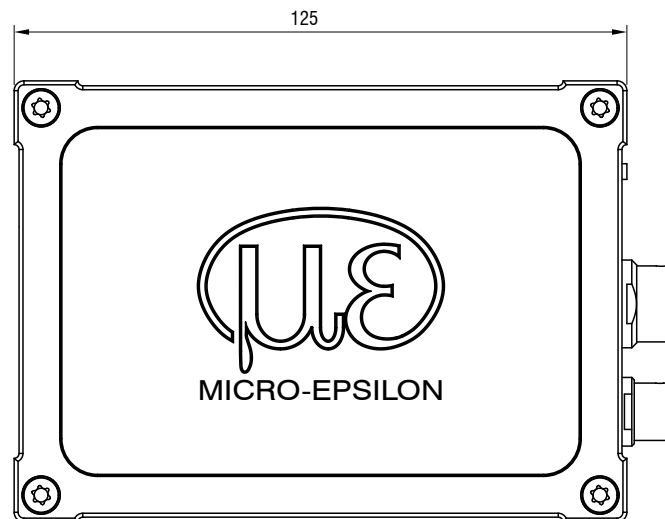
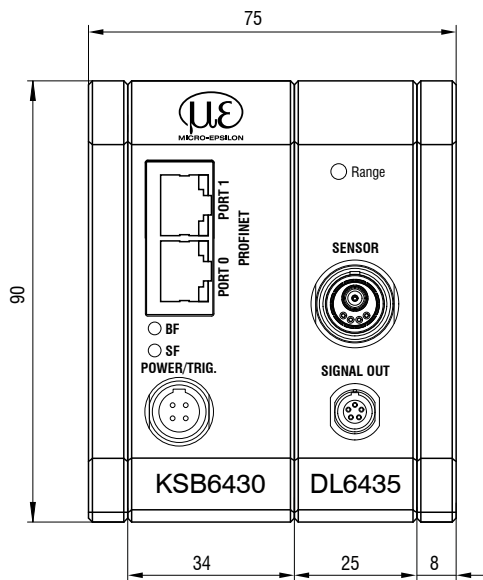

Sensor KSH5 (03)

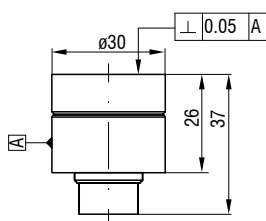

Dimensions in mm, not to scale.

Offline thickness measuring system for thin film capaNCDT TFG6220

Thickness measurement of very thin, electrically conductive film <1 mm, e.g. battery film

High-precision results thanks to automatic smoothing of the film via vacuum

Ready-to-use measuring system without installation effort

Simple operation/visualization via the freely accessible sensorTOOL software



Precise testing for reliable quality

The TFG6220 capacitive system measures the thickness of electrically conductive film, e.g. battery film, with maximum precision. A vacuum device sucks in the object to be measured, smooths it and thus ensures optimum, wrinkle-free support. In this way, the measurement can be performed with the greatest possible precision.

The TFG6220 consists of a measuring bracket including capacitive sensors and an external controller unit. It is used for quality inspection of offline random samples for thickness measurement. Pre-assembled and ready for use, this capacitive measuring system can be started quickly.

Precision at the touch of a button

The sensorTOOL software offers a user-friendly interface for operating the capaNCDT TFG. It enables the user to perform the measurements and to display and output measured data. The software is available free of charge at www.micro-epsilon.com/download.

The thickness is calculated by offsetting two opposing high-resolution capacitive sensors. In contrast to tactile measuring principles, the thickness measurement is always highly reproducible at the same location. High-precision results are achieved by automatically smoothing the test film using a vacuum device. The measuring object is not damaged in the process. The measurement is taken from two sides onto the measuring insert, which serves as a reference surface. This allows the system to be balanced to zero before the thickness measurement.

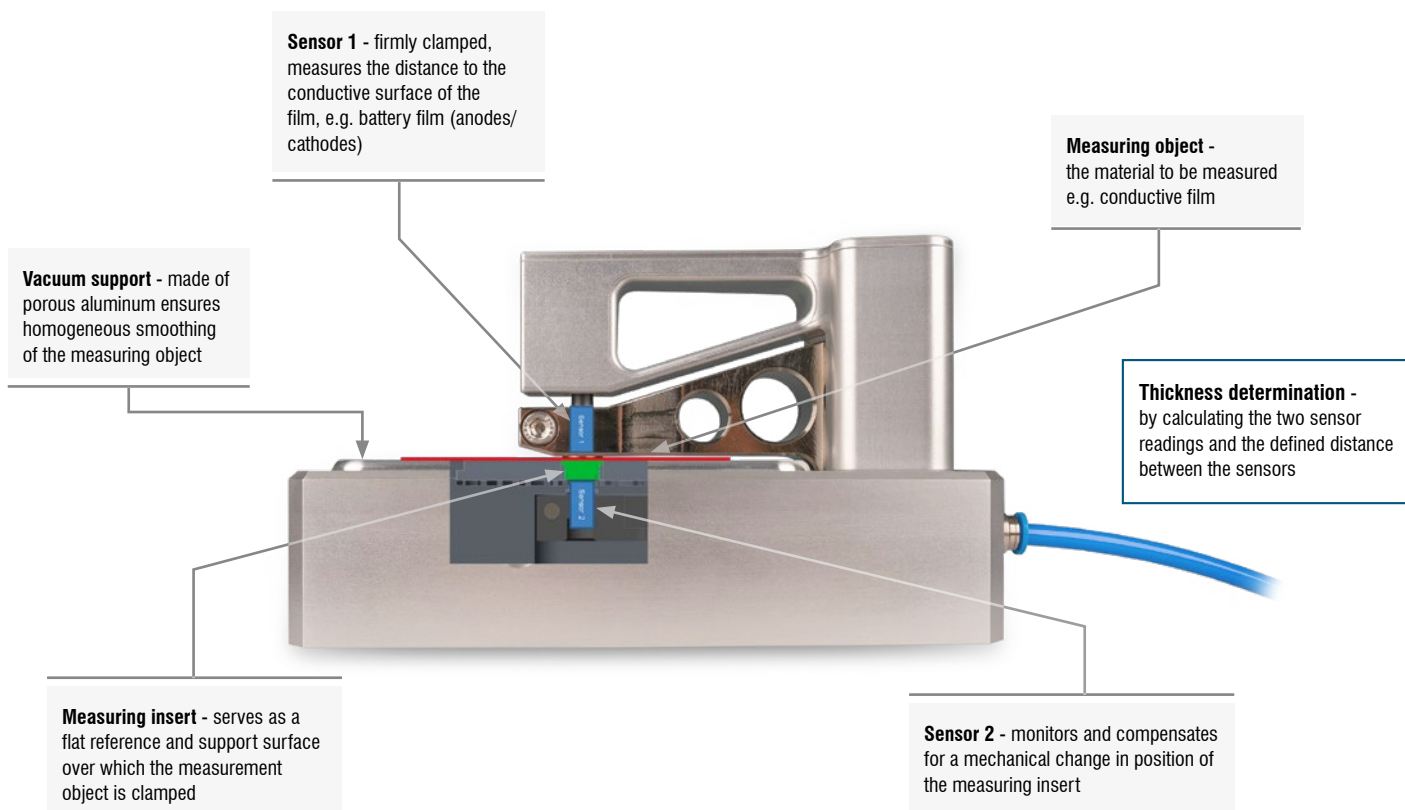

Model		TFG6220
Resolution		10 nm ^[1]
Max. measuring object/film thickness		< 1 mm
Measuring rate		100 Hz with median filter width 7
System accuracy ^[2]		up to 0.2 μm
Warm-up time		60 min
Compressed-air connection		Ø 6 mm
Power consumption		6.3 W (24 V)
Supply voltage		12 ... 36 VDC (nominal value 24 VDC)
Protection class (DIN EN 60529)		IP40
Temperature range	Storage	-10 ... 60 °C
	Operation	18 ... 25 °C
Measuring object		Electrically conductive material ^[3]
Recommended target size (flat)		110 mm x 110 mm
Special features		Throttle valve and short connection hose are included in the scope of delivery. Vacuum pump and hose between throttle valve and vacuum pump are not included. Recommended data: Vacuum 50 ... 100 mbar, pump speed max. 2 m ³ /h (at 50 Hz)

^[1] 10 nm at 100 Hz

^[2] Depending on the target object to be measured; maximum accuracy can be achieved by means of a positioning frame and zeroing of the system.

^[3] Electrical conductivity > 10⁶ S/m

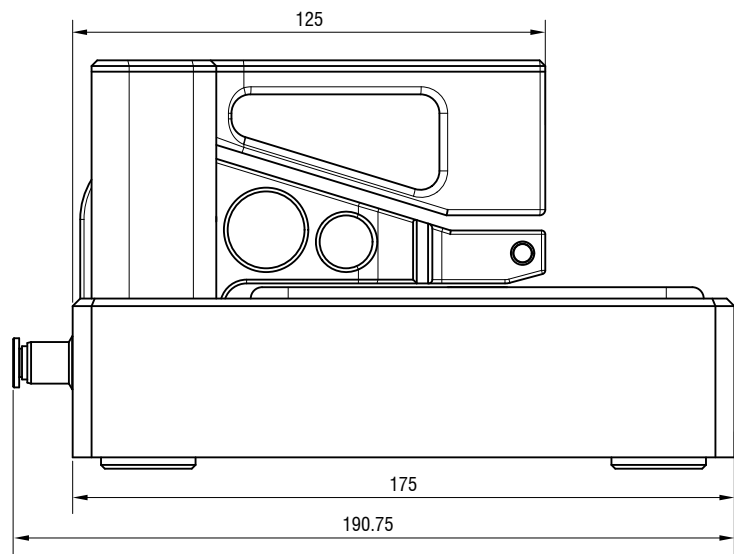
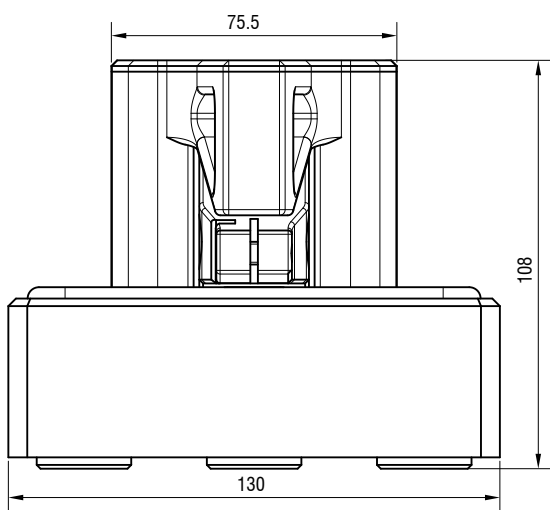

Dimensions in mm, not to scale.

Scope of supply

- Controller DT6220+2x DL6230
- Measuring bracket with sensors
- Power supply unit
- Ethernet cable
- Power supply cable
- Throttle valve + short piece of hose
- Case
- Dust cover
- Setup guide
- Protocol

Not supplied:

- Vacuum pump with a maximum final vacuum of 50 – 100 mbar
- Compressed air hose (6 mm) for connecting the vacuum pump and thickness gauge plate

Further sensor applications

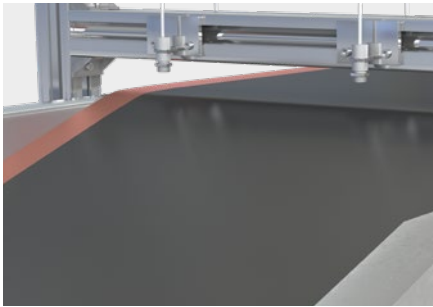

Temperature measurement during coating
Infrared pyrometers from Micro-Epsilon are characterized by maximum measurement accuracy, outstanding signal quality and extremely stable measurement signals. The robust models in the thermoMETER series are used to monitor process temperatures in coating systems.
Sensor: thermoMETER UC

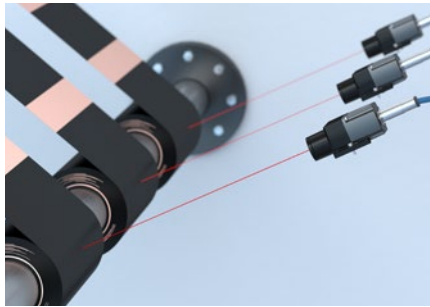

Monitoring the coil unwinding process
Laser distance sensors from the optoNCDT ILR3800 series monitor the winding and unwinding of coils. As the diameter constantly increases or decreases, the distance between the coil and the sensor, which is reliably and precisely monitored by the sensors, changes as a result.
Sensor: optoNCDT ILR3800

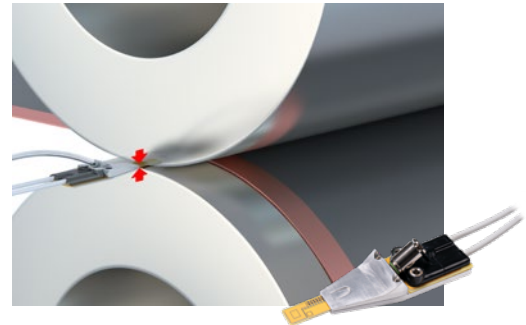

Precise control of the roller gap
Capacitive flat sensors are used for gap monitoring and control of calender and coating rollers with micrometer precision. The sensors are optimized for integration in confined installation spaces and measure between two rollers in order to control the roller gap during operation. In addition, the temperature-stable design allows use even at high ambient temperatures.
Sensor: capaNCDT CSG

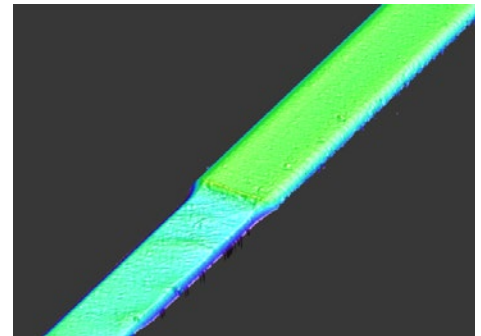
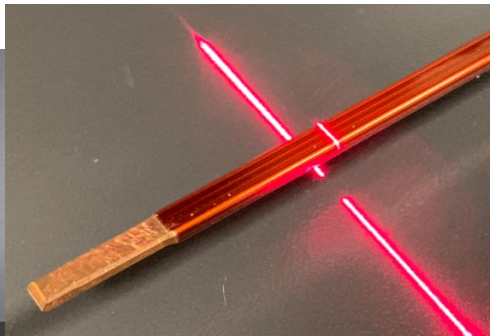

3D geometry inspection of hairpins

When manufacturing the copper wires for hairpins, various geometric parameters such as the cross-section of the wire, bending angle and parallelism are checked using 3D snapshot sensors and laser scanners. Possible defects on the component and the position of the connecting wires are also monitored to ensure perfect functioning.
Sensor: scanCONTROL / surfaceCONTROL 3500